

Rowan University

Rowan Digital Works

Theses and Dissertations

6-22-2016

Determination of non-nuclear alternative to the nuclear density gauge through laboratory and field testing

Janine Abyad
Rowan University

Follow this and additional works at: <https://rdw.rowan.edu/etd>



Part of the [Geotechnical Engineering Commons](#)

Recommended Citation

Abyad, Janine, "Determination of non-nuclear alternative to the nuclear density gauge through laboratory and field testing" (2016). *Theses and Dissertations*. 1703.

<https://rdw.rowan.edu/etd/1703>

This Thesis is brought to you for free and open access by Rowan Digital Works. It has been accepted for inclusion in Theses and Dissertations by an authorized administrator of Rowan Digital Works. For more information, please contact graduateresearch@rowan.edu.

**DETERMINATION OF NON-NUCLEAR ALTERNATIVE TO THE NUCLEAR
DENSITY GAUGE THROUGH LABORATORY AND FIELD TESTING**

by

Janine Abyad

A Thesis

Submitted to the
Department of Civil Engineering
College of Engineering
In partial fulfillment of the requirement
For the degree of
Master of Science in Civil Engineering
at
Rowan University
September 25, 2015

Thesis Chair: Yusuf Mehta, Ph.D.

© 2016 Janine Abyad

Dedication

I would like to dedicate this thesis to my dad, family, professors and friends.

Acknowledgments

I would like to thank Dr. Yusuf Mehta and Dr. Ayman Ali from Rowan University, as well as Dr. Manuel Celaya from Advanced Infrastructure Design for their assistance in my work. I would also like to thank Eileen Sheehy from the New Jersey Department of Transportation and my thesis committee, including Dr. Huiming Yin from Columbia University. I would also like to acknowledge the New Jersey Department of Transportation and the Federal Highway Administration for funding this project. The contents of the thesis reflect the views of the author, who is responsible for the facts and accuracy of the data presented within. The contents do not reflect the official views or policies of the New Jersey Department of Transportation. This thesis does not constitute a standard, specification, or regulation.

Abstract

Janine Abyad

DETERMINATION OF NON-NUCLEAR ALTERNATIVE TO THE NUCLEAR DENSITY GAUGE THROUGH LABORATORY AND FIELD TESTING

2015-2016

Yusuf Mehta, Ph.D.

Master of Science in Civil Engineering

Pavement performance is dependent on the compaction quality of unbound subgrade and base/subbase layers beneath flexible pavements. Pavement distresses can be linked to compaction defects within these layers. In current practice, the New Jersey Department of Transportation (NJDOT) utilizes the nuclear density gauge (NDG) for evaluating compaction quality based on minimum density requirements, typically 95% of the Proctor maximum dry density (MDD). However, there are concerns with using the NDG. The goal of this study was to replace the NDG with non-nuclear alternative method(s) as acceptance tools during field compaction. To achieve this, a laboratory procedure for compacting large samples was developed to facilitate testing using the Briaud compaction device (BCD), light weight falling deflectometer (LWD), and dynamic cone penetrometer (DCP) on two subgrade soils, dense graded aggregate (DGA), and recycled concrete aggregate (RCA). Each device was evaluated for their sensitivity to moisture, compaction effort, aggregate type, and time. A multiple linear regression model to predict DCP field measurements was developed and calibrated using field data to determine the minimum recommended DCP values that would ensure adequate field compaction. Using the proposed acceptance criteria, a draft specification was developed. It was concluded that the DCP is an adequate tool to replace the NDG and highly dependent on aggregate moisture content and gradation characteristics (% passing sieves No. 4 and No. 200).

Table of Contents

Abstract	v
Chapter 1: Introduction	13
1.1 Problem Statement	13
1.2 Study Objectives	15
1.3 Thesis Organization	15
Chapter 2: Review of Literature	17
2.1 Introduction.....	17
2.2 Modulus-Based Method for Compaction Quality Control	17
2.2.1 Compaction of Large Aggregate Samples for Modulus-Based Laboratory Testing.....	19
2.2.2 Effect of Different Measured Parameters on Modulus-Based Devices/Methods	22
2.2.3 Correlation between Representative Laboratory and Field Moduli.....	28
2.3 Development of Modulus-Based Construction Specifications	30
2.4 Summary	33
Chapter 3: Basis for Selecting Devices for Evaluation.....	35
3.1 Introduction.....	35
3.2 Ranking of Selected Devices	35
3.2.1 Past Experiences with Alternative Devices	36
3.2.2 Alternative Devices Repeatability and Time Needed for Measurements	41
3.2.3 Data Processing and Interpretation Requirements for Alternative Devices	45

Table of Contents (Continued)

3.2.4 Sensitivity of Alternative Devices to Environmental Factors, Accuracy and Ease of Use	48
3.2.5 Cost of Utilizing Alternative Devices	52
3.2.6 Alternative Devices Ability to Account for Lower Layer Properties	53
3.2.7 Alternative Devices Ability to Correlate Representative Laboratory and Field Moduli	56
3.2.8 Alternative Devices Ability to Account for Field Moisture and Density Variability	59
3.2.9 Sensitivity of Alternative Devices to Various Levels of Compaction	62
3.2.10 Overall Ranking of Alternative Devices	64
3.3 Survey of State DOTs, Contractors and Manufacturers	66
3.4 Description of Selected Devices	72
3.4.1 Briaud Compaction Device (BCD)	72
3.4.2 Light Weight Falling Deflectometer (LWD)	74
3.4.3 Dynamic Cone Penetrometer (DCP)	76
Chapter 4: Materials Description	78
4.1 Introduction	78
4.2 Material Properties	78
4.2.1 Gradation	78
4.2.2 Moisture-Density Relationship	79
Chapter 5: Laboratory Sample Preparation & Testing Methodology	82
5.1 Introduction	82
5.2 Laboratory Sample Preparation Procedure	82
5.2.1 Drying of Selected Aggregates	83

Table of Contents (Continued)

5.2.2	Determined Moisture Content of Aggregates	83
5.2.3	Mixing and Placement of Aggregates	84
5.2.4	Compaction of Aggregates.....	85
5.2.5	Verified Compaction Quality.....	86
5.3	Laboratory Testing Plan.....	89
5.3.1	Effect of Moisture Content	89
5.3.2	Effect of Compaction Effort	89
5.4	Field Testing Plan	91
5.4.1	Selected Field Sections	91
Chapter 6: Analysis of Laboratory Testing Results		92
6.1	Introduction.....	92
6.2	Effect of Moisture Content	92
6.3	Effect of Compaction Effort	98
6.4	Effect of Testing Time on Accuracy and Repeatability of Selected Devices.....	103
6.5	Precision of Measurements	109
6.4	Summary of Findings.....	111
Chapter 7: Development of DCP Multiple Linear Regression Model.....		113
7.1	Introduction.....	113
7.2	Separation of Collected Laboratory Data.....	113
7.3	Model Formulation	114
7.4	Development of Revised Model	115
7.5	Attempts to Improve Final Prediction Model	119

Table of Contents (Continued)

7.6 Final Model Validation	127
7.7 Calibration of Final Prediction Model Using Field Data	131
7.8 Recommended Minimum DCP Acceptance Criteria	134
Chapter 8: Development of DCP Draft Specification.....	138
8.1 Introduction.....	138
8.2 Previously Developed DCP Specifications.....	138
8.2.1 Minnesota Department of Transportation (MnDOT).....	138
8.2.2 Missouri Department of Transportation (MoDOT).....	141
8.2.3 Indiana Department of Transportation (INDOT).....	142
8.2.4 NCHRP Project 10-84.....	144
8.3 Development of DCP Draft Specification	146
8.3.1 Device and Materials	147
8.3.2 DCP Test Procedure.....	148
8.3.3 Acceptance Criteria.....	149
8.3.4 Document Results	152
Chapter 9: Conclusions and Recommendations.....	153
9.1 Conclusions.....	153
9.2 Recommendations.....	157
Appendix A: Survey of Alternative Devices	164
Appendix B: Compaction Quality Control of Unbound Subgrade and Base/Subbase Layers Through Use of the Dynamic Cone Penetrometer	183

List of Figures

Figure	Page
Figure 1. Initial BCD with Corresponding Plan View of Plate.....	74
Figure 2. Final Prototype of BCD.....	74
Figure 3. Schematic of the DCP	77
Figure 4. Particle Size Distributions Obtained for Selected Aggregates	79
Figure 5. Moisture-Density Relationships for Selected Aggregates.....	81
Figure 6. Equipment Used for Sample Preparation;	88
Figure 7. Effect of Moisture Content on Testing Results; (a) NDG Results, (b) BCD Results, (c) LWD Results; and (d) DCP Results	97
Figure 8. Effect of Compaction Effort on Testing Results; (a) NDG Results, (b) BCD Results, (c) LWD Results; and (d) DCP Results	102
Figure 9. Effect of Delayed Testing on Testing Results; (a) NDG Results, (b) BCD Results, (c) LWD Results; and (d) DCP Results	108
Figure 10. Verification of DCP Prediction Model; (a) Predicted vs. Measured DCP Values; and (b) Distribution of Relative Error Values	130
Figure 11. Computational Procedure Utilized for Computing NAT-1 Aggregates Field Correction Factor	133
Figure 12. Example of Computed Minimum DCP Value for NJDOT NAT-1 Aggregates	136
Figure 13. InDOT DCP Acceptance Criteria Based on MDD and OMC of Soil	144

List of Tables

Table	Page
Table 1. Past Experiences with Alternative Devices	41
Table 2. Alternative Devices Repeatability and Time Needed for Measurements	45
Table 3. Data Processing and Interpretation Requirements for Alternative Devices	48
Table 4. Sensitivity of Alternative Devices to Environmental Factors,.....	52
Table 5. Cost of Utilizing Alternative Devices.....	53
Table 6. Alternative Devices Ability to Account for Lower Layer Properties	56
Table 7. Alternative Devices Ability to Correlate Representative Laboratory and Field Moduli.....	59
Table 8. Alternative Devices Ability to Account for Field Moisture and Density Variability.....	62
Table 9. Sensitivity of Alternative Devices to Various Levels of Compaction	64
Table 10. Evaluation of Alternative Devices Based on all Criteria	65
Table 11. Evaluation of Alternative Devices Based on Non-Cost Criteria	66
Table 12. Surveyor Ranking of Alternative Device Attributes.....	69
Table 13. Surveyor Opinions on the GeoGauge	70
Table 14. Surveyor Opinions on the DCP	70
Table 15. Overall Surveyor Ranking of Alternative Devices	71
Table 16. Surveyor Opinions on Transitioning.....	72
Table 17. Target Moisture and Density Values Utilized	90
Table 18. Effect of Testing Time on NDG Moisture Content	107
Table 19. Standard Error of the Mean of the Results Measured from all Devices (Expressed as a Percent of the Mean Value).....	110

Table 20. Initial and Revised DCP Prediction Models	118
Table 21. Actual Measured Moisture Content of Prepared Samples	120
Table 21. Prediction Model Using 80% of Data.....	122
Table 22. Prediction Model Using 70% of Data.....	124
Table 23. Prediction Model Using NAT-1 & NAT-2 Data	126
Table 24. Prediction Model Using DGA & RCA Data	127
Table 25. Recommended Minimum DCP Values for Ensuring Satisfactory Field Compaction.....	137
Table 26. MnDOT Maximum Seat and DPI Values [32]	141
Table 27. InDOT Minimum Required DCP Values [33].....	143
Table 28. NCHRP Material Gradation Requirements [16].....	145
Table 29. NCHRP Moisture Content Requirements [16]	145
Table 30. NCHRP Relative Density Requirements for Compaction [16]	146
Table 31. NJDOT Materials Specification.....	150
Table 32. Minimum Acceptable DCP Values Based on Gradation.....	151
Table 33. Minimum Acceptable DCP Values Based on Gradation & Moisture Content.....	152

Chapter 1

Introduction

1.1 Problem Statement

Naturally existing soil and quarry-produced aggregates play a crucial role in the performance of highway infrastructure. These materials are typically used to construct the subgrade and unbound base/subbase layers beneath rigid and flexible pavements. Therefore, during the construction of these pavements, it is essential to properly compact subgrade and unbound base/subbase layers to suitable density levels to ensure satisfactory pavement performance. In other words, any compaction defects in these pavement layers usually result in distresses in the upper hot mix asphalt (HMA) or Portland cement concrete (PCC) layers. Distresses in these layers generally correlate to poor field performance of these pavements when exposed to loadings caused by passing vehicles.

In the current state of practice, most departments of transportation (DOTs) employ performance specifications as a means for compaction quality control of unbound base/subbase layers in pavement construction. These performance specifications require contractors to compact soil layers to a targeted density level. The field density of the compacted layers are measured and compared to the target density, which is typically 95% of the Proctor maximum dry density (MDD). Currently, the primary tool used for measuring field density of compacted subgrade and unbound base/subbase layers is the nuclear density gauge (NDG). Highway agencies, such as the New Jersey Department of

Transportation (NJDOT) currently use the NDG for determining the field density and moisture of embankments, subbase, and base courses [1].

The NDG is a relatively straightforward device that provides accurate density measurements in a timely manner. The device's portability and practicality aid the widespread use of the NDG. Despite the popularity and advantages of the NDG, there are several concerns and safety risks associated with using this device. For example, there are many strict regulations for using the NDG such as specific transportation, maintenance, and storage methods/procedures only appropriate for nuclear devices. These regulations also require having trained licensed personnel present to operate the NDG during the compaction quality control stage of pavement construction. These strict regulations and requirements make implementing the NDG challenging and expensive. In addition to the strict regulations associated with the device, there are many safety concerns when using the NDG. As an example, while performing testing with the device the operator may be subjected to harmful radiation produced by the NDG. Therefore, the NDG can pose a safety risk to operators.

In addition, one of the main concerns with using the NDG is that the device is limited to measuring a density value as opposed to a modulus or design-specific value that can be used during the design stage of pavement construction. To further elaborate, from a design perspective, when designing pavement structures the engineer uses an assumed modulus value. However, while in the field, the quality of the pavement layers is controlled using a density value. As a result, a gap exists between the mechanistic empirical pavement design stage and the quality control stage during the construction of pavement structures. It is highly desirable to evaluate other methods/devices that can

eliminate the need for the NDG and provide design engineers with design-specific measurements that can help in avoiding over/under designed pavements.

1.2 Study Objectives

The objectives of this study are listed below as follows:

- Develop a procedure for compacting large samples in the laboratory;
- Evaluate the effect of moisture content, and compaction effort on results obtained from non-nuclear devices and the NDG using four aggregate types, two fine graded and two dense graded;
- Evaluate the effect of aggregate type and testing time (immediately, 1-day, and 2-days after compaction) on parameters measured from all devices;
- Develop a multiple linear regression model for predicting field measurements;
- Calibrate developed prediction model using measured field data;
- Develop guidelines for implementing alternative device as a quality acceptance tool; and
- Establish suitable framework for a draft specification.

1.3 Thesis Organization

This thesis is organized into nine chapters. In chapter one, problem statement, study objectives, and outline of the thesis are presented. Chapter two presents a comprehensive literature review. The literature review conducted was imperative for determining the current state of practice for compaction quality control of unbound flexible pavements. Chapter three contains the basis for selecting the devices for

additional laboratory and field evaluation. Chapter four discusses the materials utilized for this study. This chapter also provides the material characteristics determined for each aggregate type. A detailed discussion of the research approach and methodology is presented in chapter five. Chapter six discusses the results obtained from laboratory testing. This includes an analysis of the sensitivity of each device to varying moisture contents and compaction efforts applied to the samples as well as different aggregate types and delayed testing. In chapter seven, the development and calibration of the DCP multiple linear regression model is discussed. In addition, a recommended minimum DCP acceptance criteria is presented in this chapter. Chapter eight discusses the proposed draft specification for use of the DCP for compaction quality control. Finally, chapter nine presents the conclusions and recommendations made for this study.

Chapter 2

Review of Literature

2.1 Introduction

This chapter includes a comprehensive discussion of previous studies conducted on modulus-based devices/methods as tools for evaluating unbound subgrade and base/subbase pavement layers. The previous studies mentioned focus on the compaction of large aggregates samples as well as the effects of different measured parameters on these modulus-based devices/methods. In addition, correlations that have been developed between representative laboratory and field moduli and previously developed modulus-based specifications for using these devices during the compaction quality control stage of unbound pavement layers are also presented in this chapter.

2.2 Modulus-Based Method for Compaction Quality Control

Researchers have conducted studies on different modulus-based devices/methods as tools for evaluating unbound subgrade and base/subbase pavement layers. In a study done by Lenke et al. [2] the GeoGauge was evaluated as a potential alternative to the NDG for compaction quality control during pavement construction. In this study, laboratory tests were conducted using the GeoGauge on different dry sand and cohesive soil materials. These tests were performed to determine if the GeoGauge measurements were consistent with theoretical and empirical soil mechanics concepts. Based on the results of this study, it was reported that the GeoGauge could successfully measure the modulus of the compacted field layers. However, the device was reported problematic when used to obtain targeted stiffness values in the laboratory. Ultimately, these

problems were attributed to the dynamic nature of the measurements obtained, and the associated constraints of the device. Lenke et al. [2] also reported that any future specifications developed for the GeoGauge might require specific field moisture control. In addition, these specifications may require field compaction equipment with stiffness monitoring using the GeoGauge.

Previous testing was also performed by Alshibli et al. [3] to examine the GeoGauge as well as the light weight falling deflectometer (LWD) as quality control-quality assurance (Q_c-Q_a) devices for testing subgrades, base course, and compacted soil layers. Both devices along with the dynamic cone penetrometer (DCP), and static plate load test (PLT) were used to conduct testing on compacted laboratory samples. These laboratory samples consisted of silty clay, clayey silt, cement-treated clay, sand, gravel, recycled asphalt pavement, and limestone aggregates. Based on the testing results, it was reported that both the GeoGauge and LWD could be used to determine the laboratory elastic modulus of these compacted layers. It is to be noted that Lenke et al. [2] also drew similar conclusions, further proving the success of the GeoGauge in measuring the modulus of compacted soil layers.

Studies conducted by Weidinger et al. [4] evaluated the use of the Briaud compaction device (BCD) as a field compaction quality control device for compacted soil. In this study, a series of laboratory tests were conducted using the BCD on compacted silt materials. In addition to the BCD tests, ultrasonic pulse velocity tests were performed on the same compacted silt samples to obtain the elastic moduli (Young's and shear moduli) of the material. It should be noted that repeated BCD testing was performed to determine the device's ability to replicate results on the samples. The

modulus values obtained from the BCD were then compared to the results of the ultrasonic pulse velocity tests. Based on the results of this study, Weidinger et al. [4] concluded that the BCD modulus correlated well to ultrasonic pulse velocity results with a coefficient of determination (R-squared) of 0.8 or better. In addition, the BCD showed a variation of 4% of the mean; proving the device could accurately measure the modulus of compacted soil samples.

In a study done by Chen et al. [5] the DCP was assessed for its ability to evaluate base and subgrade layers. In this study, over 60 DCP tests were conducted on two test pavements. Results of these tests were used to validate the pre-established empirical equations for computing moduli from data obtained using the DCP. Chen et al. [5] also evaluated the effect of the test procedure on the DCP results. These results were correlated to results obtained using the multidepth deflectometer (MDD), falling weight deflectometer (FWD), and laboratory results. From this study, it was concluded that DCP values were dependent on the test procedure, inevitably affecting the results by approximately 10%. The subgrade moduli determined in the laboratory were only slightly higher than results from the DCP and FWD-MDD tests. In addition, the modulus results from the DCP and empirical equations were comparable to FWD and MDD modulus results. Overall, the results of this study confirmed that the DCP could be utilized to evaluate the compaction quality of subgrade and base/subbase layers.

2.2.1 Compaction of Large Aggregate Samples for Modulus-Based Laboratory Testing

As a means for evaluating different modulus-based devices/methods, researchers have utilized laboratory compacted aggregate samples in their studies. The laboratory

prepared samples allowed researchers to simulate different field unbound subgrade and base/subbase layers in which these modulus-based devices/methods would be used to test. In addition, the compacted samples allowed researchers to study the effects of different measured parameters on these modulus-based devices/methods, to be discussed in the following section.

As mentioned in the previous section, Alshibli et al. [3] conducted studies to evaluate the GeoGauge and LWD as Q_c - Q_a devices for testing subgrades, base courses, and compacted soil layers. In this study, testing was conducted at the Louisiana Transportation Research Center (LTRC) laboratory. The compacted aggregate samples utilized were prepared in two identical boxes measuring 60-inches (152.4-cm) in length, 36-inches (91.4-cm) wide, and 36-inches (91.4-cm) deep. At the bottom of each prepared sample was an 8-inch (20.3-cm) thick clay layer, compacted at optimum moisture content (OMC), that served as the subgrade layer for the samples. Two additional 8-inch (20.3-cm) thick lifts were then compacted above the clay layer using the desired soil/base material. Each aggregate sample and corresponding base layer was compacted inside the box using a Wacker Packer plate compactor. Both the GeoGauge and LWD were then used to conduct testing on the compacted samples. In addition, testing was also conducted on the samples using the DCP and PLT. Using the laboratory prepared samples, Alshibli et al. [3] concluded that both the GeoGauge and LWD could be used to determine the elastic modulus of the compacted aggregates.

In a study done by Abu-Farsakh et al. [6] a series of laboratory and field tests were conducted to evaluate the use of DCP in the Q_c - Q_a process during the construction of pavement layers. In this study, laboratory testing was conducted on twenty-three

aggregate samples prepared at different moisture contents and compaction levels. Silty clay and clayey silt materials, typically used in the construction of highway embankments, were used to prepare the compacted samples. Additional materials, such as sand, crushed limestone, and reclaimed asphalt pavement (RAP), were also utilized for laboratory testing. Similar to Alshibli et al. [3], the samples were prepared at the LTRC in two boxes measuring 60-inches (152.4-cm) in length, 36-inches (91.4-cm) wide, and 36-inches (91.4-cm) deep. The samples were compacted in two 8-inch (20.3-cm) thick lifts using a small Bosch compactor and a Wacker Packer plate compactor. After each layer was compacted, DCP tests as well as one PLT test was conducted on the sample to determine the elastic modulus of the aggregate layer. Based on the results of this study, Abu-Farsakh et al. [6] concluded that DCP could be used to determine the stiffness and strength of pavement layers if used for Q_c - Q_a during pavement construction.

Murad et al. [7] also conducted laboratory and field testing to evaluate the DCP, LFWD, and GeoGauge for use in determining the strength/stiffness of pavement layers and embankments. Similar to both Alshibli et al. [3] and Abu-Farsakh et al. [6], the aggregate samples were prepared at the Geosynthetic Engineering Research Lab (GERL) at the LTRC using two identical boxes measuring 60-inches (152.4-cm) in length, 36-inches (91.4-cm) wide, and 36-inches (91.4-cm) deep. However, unlike Alshibli et al. [3], who compacted samples above a 7.9-inch (20-cm) thick clay layer, the samples in this study were compacted above a 12-inch (30.5-cm) thick clay layer. In addition, all aggregate samples were compacted in two 8-inch (20.3-cm) thick lifts for a total depth of 16-inches (40.6-cm). A small Bosch compactor as well as a Wacker Packer plate compactor was utilized for compaction. Upon completion of compaction a series of DCP,

LFWD, and GeoGauge tests were conducted on the samples. Standard testing using the PLT and California bearing ratio (CBR) were also conducted on the prepared samples. Based on the results of this study, Murad et al. [7] concluded that the measurements obtained from the DCP, LFWD, and GeoGauge correlated well to those obtained from the standard PLT and CBR tests.

Herath et al. [8] also evaluated the use of the DCP for determining the resilient modulus of subgrades soils. In this study, twelve large aggregate samples were prepared using two aggregate types, subjected to different moisture and compaction levels. The samples were compacted in large boxes measuring 59.1-inches (150-cm) in length, 35.4-inches (89.9-cm) wide, and 23.4-inches (59.9-cm) deep. An electric jackhammer was then used to compact the samples in 7.9-inch (20.1-cm) thick lifts and a series of DCP and resilient modulus tests were then conducted on the samples. The results from testing were used to develop two prediction models to determine the resilient moduli of subgrade soils. The laboratory testing results showed that the resilient modulus values measured through both prediction models corresponded well with the resilient modulus values obtained through the resilient modulus tests. Based on the results of this study, Herath et al. [8] concluded that the DCP could successfully determine the resilient moduli of subgrade soils.

2.2.2 Effect of Different Measured Parameters on Modulus-Based Devices/Methods

Researchers have also conducted studies to determine the effect of different measured parameters on modulus-based devices/methods. As mentioned in the previous section, laboratory samples were prepared at varying moisture contents, compaction

levels, and aggregate types in which the modulus-based devices were then tested on. The laboratory compacted samples prepared in these studies allowed researchers to assess the performance of each device/method when exposed to different types of subbase/base layer conditions.

In the study done by Lenke et al. [2], the GeoGauge was evaluated for compaction quality control during the construction of pavements. Testing using the GeoGauge was conducted on different dry sand and cohesive soil materials to determine the stiffness of each material. The materials utilized in this study composed of dry granular cohesionless silica sands as well as cohesive silty-sand materials. Based on the laboratory testing results, Lenke et al. [2] confirmed that the GeoGauge measured the stiffness of the different aggregate types. In addition, the results obtained from the cohesive soil samples indicated that as moisture content in the sample increased, the stiffness of the soil decreased, thus proving that the GeoGauge is sensitive to changes in moisture content. In addition, Lenke et al. [2] suggested that any specifications developed for the GeoGauge may require specific field moisture control.

In the study conducted by Alshibli et al. [3], laboratory testing was conducted to evaluate the GeoGauge and LWD for use in the Q_c - Q_a stage during highway construction. As mentioned in the previous sections, testing was performed on laboratory compacted samples prepared in two identical boxes, above an 8-inch (20.3-cm) thick clay layer. The aggregate types utilized in this study included silty clay, clayey silt, cement-treated clay, sand, gravel, RAP, and limestone aggregates. Each aggregate sample and its corresponding base layer was compacted within the boxes and subjected to a series of GeoGauge, LWD, DCP, and PLT tests. Throughout laboratory testing the cement-treated

clay samples were studied to determine the strength improvement of the compacted layers with time and the effect of moisture on the GeoGauge and LWD. The results indicated that the GeoGauge and LWD were able to determine an increase in modulus over the course of 11 days for both the 2% and 4% cement-treated clays. However, for the 6% and 8% cemented-treated clays, the GeoGauge indicated a decrease in modulus over time. In addition, the DCP penetration rate for the cement-treated clays decreased with time. Based on the results of this study, Alshibli et al. [3] concluded that the GeoGauge and LWD were sensitive to changes in moisture and testing time, specifically in cement-treated clay materials. The lack of moisture within the materials caused shrinkage cracks at the surface of the samples inevitably affecting the GeoGauge and LWD measurements. In addition, the testing results varied between the different materials, thus proving the devices' sensitivity to changes in aggregate type.

Hossain et al. [9] conducted laboratory and field testing to evaluate the LWD for determining the moduli of existing pavement layers. In this study, LWD as well as GeoGauge and DCP testing was conducted on seven pavement sections in Virginia. These sections included three compacted subgrades layers, one compacted base layer, and three existing gravel roads. In addition, small scale laboratory testing was conducted on two soil types to determine the effect of moisture content and density on the measured soil moduli. Ultimately the testing results obtained from the LWD were compared to those obtained from the GeoGauge and DCP. The testing results in this study indicated that the stiffness modulus increased as the density of the materials increased for both the LWD and GeoGauge measurements. In addition, the highest correlation between density and soil modulus was observed between the LWD and GeoGauge ($R^2 = 0.44$). However,

no clear relationship could be determined between moisture content and soil stiffness for the subgrade, base aggregates, and gravel road materials. Furthermore, no trend could be determined between moisture content and soil stiffness for the LWD or GeoGauge. However, there was a strong influence of moisture ($R^2 = 0.97$) on the DCP measurements for all materials tested, such that as the moisture content in the material increased the stiffness measurements decreased.

Murad et al. [7] also evaluated the GeoGauge, LFWD, and DCP for use in determining the strength/stiffness during pavement construction. In this study, aggregate samples were prepared and compacted using a Bosch and Wacker Packer plate compactor into boxes above a 12-inch (30.5-cm) thick clay layer. The compacted laboratory samples were then exposed to GeoGauge, LFWD, and DCP tests as well as PLT and CBR tests. A statistical analysis was performed on the collected data to correlate the measurements obtained from the GeoGauge, LFWD, and DCP to those obtained from PLT and CBR testing. The results of this study showed good correlations between the testing results obtained from the GeoGauge, LFWD, and DCP to those obtained from the PLT and CBR testing. In addition, better correlations were obtained from the field testing measurements than those obtained through laboratory testing as a result of inconsistent compaction of the laboratory samples. The laboratory testing results indicated that GeoGauge was sensitive to the presence of moisture within the samples as well as testing time, specifically for cement-treated and lime-treated soils. Nonetheless, the GeoGauge testing results were successfully correlated to the PLT and CBR measurements. Murad et al. [7] also concluded that LFWD and DCP showed better correlations than the GeoGauge for both field and laboratory testing. Based on the results of this study, it was concluded that

the GeoGauge, LFWD, and DCP could accurately predict the moduli obtained from the FWD and CBR tests. However, all devices were influenced by the presence of moisture during compaction and time of testing.

In a study done by Nazzal et al. [10] several different highway sections in Louisiana were used to evaluate the LWD for measuring the modulus of pavement layers and subgrades. In this study, nine test sections were constructed and tested on using the LWD in conjunction with the FWD, PLT, and DCP tests. The testing results were then collected and a linear regression analysis was performed to develop models that related FWD moduli to moduli obtained from the FWD, PLT, and DCP penetration rate. The LWD testing results were also used to develop models to predict FWD and PLT measurements. Similar to studies conducted by Alshibli et al. [3] and Murad et al. [7], the testing results in this study indicated the modulus value measured by the LWD increase with time, for cement-treated materials. In addition, Nazzal et al. [10] concluded that the LWD was influenced by the presence of moisture in the materials. The testing results also showed that the LWD modulus increased with the increase in compaction effort. It is worth noting that, Nazzal et al. [10] also suggested that the correlation between LWD elastic moduli and dry unit weight of the material depended on the aggregate material tested.

Petersen et al. [11] evaluate the use of the LWD for measuring the stiffness of subgrade soils. In order to evaluate the LWD in this study, stiffness measurements were recorded at different locations along nine embankment projects. In addition to measuring the stiffness of the soils, density, and moisture measurements were taken at select locations throughout the projects. The data collected during testing was used to develop

correlations between resilient moduli and field moisture content and density. Laboratory soil samples were also collected to determine the resilient moduli of the material at varying density and moisture contents. Based on the testing results, Petersen et al. [11] concluded that the effect of compaction effort on the resilient moduli was dependent on the aggregate type and moisture level. Overall results suggested that the modulus of the material increased with an increase in compaction effort. Petersen et al. [11] also concluded that the modulus of soils decreased as the moisture content in the material increased. It is worth noting that similar trends were observed between the different soil types tested.

In the study done by Herath et al. [8] laboratory and field testing was conducted using the DCP to predict the resilient modulus of subgrade soils. In order to assess the DCP, twelve large cohesive soil samples and six field sections from two existing pavements were utilized for testing. A total of twenty-four laboratory DCP tests and six field DCP tests were conducted and used to develop a model to predict the resilient modulus of cohesive soil. In addition, for each DCP test a resilient modulus test and soil property test was conducted on the compacted soil samples. Based on the results of this study, Herath et al. [8] concluded that the proposed prediction model accurately predicted the resilient modulus of the soil. Laboratory testing also showed that as the moisture in the samples increased the DCP penetration index (DPI) increased. In addition, as the moisture in the material increased the modulus of the material decreased, thus concluding the influence of moisture content and aggregate type of the samples on the DCP.

2.2.3 Correlation between Representative Laboratory and Field Moduli

In addition to the studies conducted to evaluate the effect of different measured parameters on the devices' testing results, studies have also been performed to develop correlations between representative laboratory and field moduli. As an example, Briaud et al. [12] developed correlations between representative laboratory and field moduli using the BCD. In this study, both laboratory and field tests were conducted using the BCD on the same soil samples. Results from field tests were then compared to PLTs and laboratory testing results. In order to determine if the device could accurately capture field modulus values the results were compared to one another. Based on the results of this study, Briaud et al. [12] concluded that the BCD laboratory results could successfully be correlated to field moduli results.

Nazzal et al. [10] conducted field testing on several highway sections to evaluate the use of the LWD in measuring in-situ modulus of pavement layers and subgrades. In this study, nine field sections were constructed and tested using the Prima 100 model-LWD. FWD, PLT, and DCP tests were also utilized in this study to provide reference measurements for comparing the LWD results. The results from field testing helped facilitate the development of a linear regression model to relate LWD stiffness moduli with the moduli obtained from the FWD, PLT, and DCP penetration rate. In addition to this, multiple linear regression analyses were conducted to develop prediction models for the FWD and PLT, based on the LWD elastic moduli and soil properties (i.e., moisture content and void ratio). Nazzal et al. [10] concluded that the LWD could predict FWD, PLT, and DCP values within a certain level of confidence. The developed prediction

models were improved when the soil properties were introduced as variables in the equation.

Mohammad et al. [13] also conducted laboratory and field testing to develop models that predict resilient moduli of soils from test results obtained from the DCP, continuous intrusion miniature cone penetrometer (CIMCPT), dynamic deflection determination (Dynalect), and FWD. The laboratory testing consisted of repeated triaxial resilient modulus tests along with compaction and physical property tests. Field testing was conducted using the DCP while statistical analysis was performed on the collected laboratory and field data. From the laboratory and field results, Mohammad et al. [13] found a correlation between predicted and measured resilient moduli. Similar to Nazzal et al. [10], the prediction model developed was improved when the soil properties (i.e., moisture content and dry unit weight) were introduced into the equation.

In the study done by Herath et al. [8], correlations were developed to predict field moduli values of subgrade soils from test parameters of the DCP. The DCP test parameters utilized included: (1) aggregate type, (2) moisture content, and (3) dry unit weight. In this study, laboratory testing was conducted on twelve large soil samples using two cohesive soil types. Field testing was also performed using the DCP at six different locations within two existing pavements. Using the results from both laboratory and field testing, Herath et al. [8] developed a model to estimate the resilient moduli of subgrade soils. Based on the developed prediction model, Herath et al. [8] concluded that the model could accurately predict data sets. It was also concluded that the DCP was successful in determining the resilient moduli of pavements and subgrade soils.

Salgado et al. [14] developed correlations between DCP test results to different soil properties (i.e., dry density and moisture). Unlike the previously mentioned studies, Salgado et al. [14] did not correlate DCP results to moduli results obtained using an alternative device. Rather, in this study a series of field and laboratory tests were performed using the DCP and nuclear gauge tests. Seven construction sites were selected for field testing. These seven sections included: four clayey sands, two poor graded sands, and well-graded sand composed of clay. Testing was conducted on the same location for both devices to allow Salgado et al. [14] to compare the DCP results to the nuclear tests results. Ultimately, Salgado et al. [14] concluded that the penetration rate of the soil decreased with an increase in dry density. In addition, the penetration rate increased as the moisture content increased. In the case of clayey sands, it was concluded that the aggregate dry density could be used to predict field DCP results. Due to the uncertainty of the DCP tests, Salgado et al. [14] suggested that the DCP be performed for compaction quality control in conjunction with test methods such as the nuclear gauge.

2.3 Development of Modulus-Based Construction Specifications

In addition to correlating representative laboratory and field moduli obtained from alternative non-nuclear devices, studies have also been performed to develop modulus-based construction specifications for use of these devices. For example, Petersen et al. [11] evaluated the feasibility of using the LWD for measuring the stiffness of subgrade soils. In this study, testing using the LWD was conducted on nine embankment projects. Stiffness, density, and moisture values were measured from each location to determine the resilient moduli of the soils at different moisture and density levels within the

laboratory. Based on the laboratory and field results, a model to predict resilient modulus was developed. Predicted values were then compared to actual LWD results. Petersen et al. [11] concluded that the predicted moduli, as determined from the established model (based on laboratory resilient modulus tests), did not correlate well with the in-situ stiffness measured using the LWD. As a result, a stiffness-based specification for in-situ embankment compaction quality control could not be developed.

In a study conducted by Davich et al. [15] moisture specifications for granular materials were validated for the DCP and LWD. The moisture specifications evaluated were provided by the Minnesota Department of Transportation (MnDOT). In this study, both the DCP and LWD were tested on multiple laboratory samples. The results of laboratory testing concluded that both the DCP and LWD were effective in assessing the compaction quality of the prepared samples. However, suggestions were provided to improve both device specifications. The recommendations provided by Davich et al. [15] included penetrating the sample past the subgrade layer when using the DCP. In addition, it was suggested that a DCP seating requirement was not necessary, and the acceptable amount of moisture during testing on granular subbase should be at a maximum of 10%. For the developed LWD specifications, Davich et al. [15] recommended using a falling mass of 2.2-lbs. (10-kg), a drop height of 19.7-in. (50-cm), and plate diameter of 7.9-in. (20-cm).

Nazarian et al. [16] also developed a modulus-based construction specification for compaction of earthwork and unbound aggregates using the DCP and alternatives devices. In this study, laboratory and field testing was conducted on three fine-grained soils, two sandy materials, and two unbound granular base materials at different target

moisture contents and densities. This method was chosen in order to determine the construction parameters of each geomaterial as well as establish relationships between laboratory and field moduli. Both laboratory and field test results were used to calibrate the modulus prediction models developed for the study. Based on the testing results and prediction models developed, a draft specification was proposed. The proposed specification, provided by Nazarian et al. [16], was tested and improved through additional testing on different construction projects.

Wu et al. [17] also developed and implemented a stiffness-based procedure for using the DCP as an acceptance tool for unbound materials. In this study Wu et al. [17] proposed a set of DCP unbound material acceptance criteria and standards for the Ohio Department of Transportation (ODOT). The procedure and acceptance criteria standards were based off of the findings of the Ohio Research Institute for Transportation and the Environment (ORITE) study in which data was collected and analyzed from 10 different road projects. From both studies, it was concluded that the DCP could be a viable alternative to evaluating different subgrade materials. In addition, the ORITE study suggested that adopting the DCP for unbound material acceptance specifications could greatly improve pavement performance. Based on the DCP results, a threshold for unsuitable materials and stiffness parameters for pavement design rehabilitation was also developed.

In addition to developing specifications for using the DCP, a geotechnical guide performance specifications for embankment and pavement construction was provided by White et al. [18]. These performance specifications were developed using various in-situ testing methods including intelligent compaction (IC) technologies. In this study, testing

was performed on different test areas composed of silty clay embankment fill, and crushed limestone aggregate, typically used for stabilizing backfill or pavement subbase. Testing was conducted on these areas using nuclear density moisture content tests, PLT, and DCP tests. Following testing, the DCP and PLT results were analyzed and compared to the traditional quality control methods based on nuclear density/moisture testing. The results of testing concluded that the IC technologies results could be successfully correlated to modulus results obtained using the PLT, and DCP. However, it was observed that these devices did not produce accurate results in areas with high moisture content. Based on the findings of this study, White et al. [18] provided several advantages and specifications for using IC technologies in earthwork construction quality control.

2.4 Summary

In summary, the majority of studies found throughout literature indicated that alternative non-nuclear devices could effectively evaluate the quality of compacted subgrade and base/subbase layers beneath rigid or flexible pavements. In addition, prediction models and specifications for using these devices have been established in these reports. However, most of the reports mentioned focused exclusively on validating the use of these devices for measuring the modulus of these compacted pavement layers. Validation of these devices included correlating the devices' laboratory and field moduli results to moduli results obtained through standard tests. However, in order to determine a non-nuclear alternative to the NDG, it is necessary to correlate laboratory and field moduli results of these devices to laboratory and field density values that are currently obtained using the NDG. Furthermore, a majority of literature did not comprehensively

evaluate the effect of aggregate type, moisture content, compaction effort, and delayed testing on the results obtained from these devices.

Existing specifications established in these reports concentrated on developing modulus-based specifications with values predicted using the modulus devices. In addition, the studies mentioned were limited to subgrade aggregates and did not consider materials that are typically used for constructing pavement layers.

Chapter 3

Basis for Selecting Devices for Evaluation

3.1 Introduction

The basis for selecting the devices for additional laboratory and field evaluation is presented in this chapter. This includes a detailed discussion of the procedure implemented to rank the devices based on a specific set of criteria. In addition, this chapter discusses the survey prepared and distributed to state DOTs, contractors, and manufacturers. The survey was utilized to obtain the latest feedback on the selected devices and opinions on transiting from density-based testing and towards modulus/stiffness-based methods. Finally, based on the comprehensive literature review and the survey conducted, a description of the devices selected for further laboratory and field investigation is discussed in this chapter.

3.2 Ranking of Selected Devices

In order to select the devices most appropriate for this study a ranking system was developed. The ranking system was created to better understand the performance and feasibility of using the GeoGauge, PaveTracker, BCD, various LWDs, and the DCP as quality acceptance tools for subgrade and unbound base/subbase layers. The likelihood of utilizing these devices for further laboratory and field investigation in this study was solely based on the potential each device showcased through the literature review. The ranking system implemented was based on the following nine criteria:

1. Past experiences with alternative devices;
2. Alternative devices repeatability and time needed for measurements;

3. Data processing and interpretation requirement for alternative devices;
4. Sensitivity of alternative devices to environmental factors, accuracy, and ease of use;
5. Cost of utilizing alternative devices;
6. Alternative devices ability to account for lower layer properties;
7. Alternative devices ability to correlate representative laboratory and field moduli;
8. Alternative devices ability to account for field moisture and density variability; and
9. Sensitivity of alternative devices to various levels of compaction.

Based on these 9 criteria, a ranking was established for each device and the results for each criterion are discussed in detail in the respective subsections below. Based on the results of this ranking system, the top three alternative devices that successfully met the criteria were selected for additional testing in this study. It is to be noted that the PaveTracker and PQI devices, typically used for HMA, were also included in the literature evaluation to determine their potential use for unbound materials. In addition, the ranking system may be biased towards certain devices due to the availability or unavailability of device information in regards to a specific criterion mentioned above.

3.2.1 Past Experiences with Alternative Devices

A literature review was performed on the GeoGauge, PaveTracker, BCD, LWD, and DCP to study past experiences, both good and bad, with using the alternative devices.

This literature review was necessary to identify how each device performed in previous studies. Understanding how well the devices performed (in the laboratory or field) provided insight on how the devices would have performed if selected for additional testing in this study.

Past experience with the GeoGauge indicated that the device requires similar training and operator capabilities as the NDG [19]. Therefore, if the GeoGauge were selected for this study strict regulations would still exist for using the device. Previous experiences also showed that the GeoGauge calls for prior calibrations, consisting of multiple load resilient modulus tests for specific materials, which are not performed by most agencies. These reports further suggest that the GeoGauge may be difficult to use for this study. In addition, it was reported that the results using the GeoGauge may be inaccurate if used to test thin (less than 4-inches (10.2-cm)) or thick (more than 12-inches (30.5-cm)) layers or on materials with stiffness greater than 23 MN/m. A study also recommended that the device not be used for measuring dry density, even after finding calibration factors [20]. Also, when previously tested on non-cohesive, well-graded sands, there was high variability in the GeoGauge results [20]. These observations suggested that the GeoGauge might pose problematic for this study as different types of fine and coarse materials were used for testing.

Observations have also been made in regards to challenges with using the GeoGauge. Specifically, reports have mentioned that there was difficulty in achieving adequate contact between the GeoGauge ring and the tested soils [21] [22] [23]. In order to ensure a minimum of 80% contact between the foot and the soil the device manufacturers have suggested slightly twisting the device during testing. If 80% contact

could not be achieved then the manufacturer recommended placing down a thin layer of sand. However, this thin layer of sand can inevitably impact the testing results of the device. The GeoGauge has also been problematic when calibrated in a laboratory setting as a result of specific boundary conditions, and certain soils influencing the device [2]. Based on the literature, it is evident that the GeoGauge requires similar training and use requirements as the NDG. The device also requires time in order to properly calibrate the device. Therefore, past experiences with the GeoGauge suggested that the device might be difficult to use for testing.

The pavement quality indicator (PQI) was introduced as the first non-nuclear density gauge in 1998. In past studies the device experienced several problems when exposed to moisture and could not accurately determine the density of the tested pavement. However, the device became more adept to efficiently measuring the density when exposed to moisture as a result of the development of an improved model. Although the recent pavement quality model has been deemed promising, moisture concerns still exist for the device [24]. Unfortunately, additional information regarding the past experiences could not be found for the PaveTracker. However, since both the PQI and PaveTracker perform with similar methods it can be inferred that the PaveTracker would also experience problems when exposed to different moisture contents. The concerns presented suggest that both devices might perform poorly in this study as the devices evaluated were exposed to varying levels of moisture content.

The BCD is considered one of the newer non-nuclear devices studied, for this reason there is limited information regarding the history of evaluations conducted for the device. However, from the existing tests performed using the BCD it has been identified

that there is only 0.08-inches (2-mm) of clearance when using the device. In other words, the placement and execution of the BCD must be near perfect, with small room for error, to ensure accurate results [4]. In addition, when utilized on very soft soils, the weight of the BCD may cause the strain plate to sink prior to using the device, inevitably affecting the results of testing [19]. These past studies using the BCD suggest that the device is challenging to use during testing. Therefore, if used in this study, it may be difficult to obtain accurate results if the BCD is not placed precisely. However, the 4.35-lb. (1.76-kg) weight of the device makes the BCD easy to carry and used by one operator. Overall, past studies suggest that the BCD may not provide accurate results due to the general nature of the device.

Past experiences with the LWD suggest that the device is non-destructive when used during testing, however operation of the device requires dropping a 22-lb. (10-kg) mass onto a loading plate. Although the device is defined as non-destructive, the impact caused by the falling mass can result in additional compaction or disturbances within the soil layer. For the purpose of this study, it was important that the device selected for testing did not affect the prepared samples. Therefore, this observation suggests that the LWD might inflict excess force on the samples prepared for laboratory testing.

In regards to operating the LWD, there were no reports of safety concerns associated with using the device [19]. Unlike the NDG, this allows both field inspectors and operators to remain on site during testing without any safety concerns. However, previous studies have observed high spatial variability and moisture effects on the LWD measurements. Therefore, it was recommended that the LWD not be used as a quality assurance device for compacted soils until further research is conducted to determine the

causes of these effects [9]. The high spatial variability in the LWD results indicated that the device might not generate accurate results if used for testing in this study.

Previous literature on the DCP indicated that the DCP test is a simple, rapid, and economical in-situ test for many geotechnical applications [8]. Studies using the device have concluded that the device is easy to use and provides results in a timely manner. Based on the previous success of the device, it was concluded that the DCP might be a suitable device to further investigate in this study. Little has been done in regards to measuring the resilient modulus pavement subgrade soils using the device. However, models have been successful developed for predicting the resilient modulus of subgrade soils using DCP test parameters [8]. The overall past experiences with the DCP and results of these prediction models indicate that the DCP could successfully be used for modulus based testing in this study.

Based on the comprehensive literature review conducted on the past experience of the selected devices, an overall ranking of the devices was developed and summarized in Table 1 below. The ranking in Table 1 is based on the past experiences of each device on a scale from 1 to 5; 1 being the most promising of the devices and 5 being the worst based on the criteria.

Table 1

Past Experiences with Alternative Devices

Device	Overall Past Experience	Rank
GeoGauge	<ul style="list-style-type: none"> - Difficult compared to NDG - Tedious calibration - Non-destructive 	3
PaveTracker	<ul style="list-style-type: none"> - Not very difficult or complicated to use - Sensitive to moisture, lack of available information - Non-destructive 	5 (worst)
BCD	<ul style="list-style-type: none"> - Extremely user-friendly: No calibration needed - Placement and execution must be exact - Non-destructive 	2
LWD	<ul style="list-style-type: none"> - Simple and quick procedure (comparable to DCP) - Currently not recommended for quality control/quality assurance due to high variability - Non-destructive, but may introduce additional soil compaction and disturbance 	4
DCP	<ul style="list-style-type: none"> - Successful; Simpler than NDG - Evaluation of resilient modulus not well known - Destructive 	1 (best)

3.2.2 Alternative Devices Repeatability and Time Needed for Measurements

For the purpose of this study, it was essential that the devices selected for laboratory and field evaluation produced timely results that could also be easily replicated. In order to determine the devices that adequately met these criteria, a literature review was conducted on the devices repeatability and time needed for measurements. Following the literature review, the devices were ranked accordingly.

As previously mentioned, when tested on non-cohesive, well-graded sands high variability was observed for the GeoGauge results [20]. Specifically, reports have

determined a coefficient of variation (COV) ranging from 6.1 to 9.5% for the device [6]. It should be noted that this study was completed after 54 measurements were taken at 3 different locations. However, other reports have observed excellent repeatability with the GeoGauge when measurements were taken consecutively on different soil types [25]. These observations suggest that even after repeated measurements using the GeoGauge, high variability might still be experienced within the results if not measured immediately after the initial measurement. In addition, it has been reported that the GeoGauge results were “extremely inconsistent and highly dependent on the seating procedures and the operator” [22] [26]. Despite this observation, the GeoGauge had similar or better repeatability than other in-situ test devices, with lower spatial variability than the LWD and DCP [19].

Based on previous studies using the GeoGauge reports have noted that each measurement required 75 seconds to complete, as opposed to the NDG, in which only 60 seconds is required. In addition, the time for using the GeoGauge doubles when the preparation and clean up time is considered. The observations made in these studies suggested that high variability might be experienced if the GeoGauge were to be used for additional testing. Moreover, a longer period of time will be required to obtain the results from laboratory and field testing.

The manufacturers of the PQI recommended that five readings be obtained for each area tested. Specific instructions insisted that the initial reading be measured normally and the following four readings be obtained by rotating the device to approximately 2, 5, 8, and 11 o'clock positions respectively. The five readings can then be averaged together to obtain the appropriate density value. The manufacturer of the

PaveTracker suggested a similar protocol, however, only four readings were recommended at 12, 3, 6, and 9 o'clock positions [24]. Based on these recommendations it can be inferred that individual readings for the both devices may be slightly skewed therefore more than one measurement is necessary to ensure accurate results. Two concerns arise from these recommendations, which include the amount of variability in the test results, and the additional time needed to operate both devices. In addition, the recommendations provided by the manufactures suggested that the high variability in the PQI and PaveTracker test results must be accounted for if used for this study.

According to the device manufacturers, the BCD test involves taking four measurements, 90° apart, in order to obtain an average modulus value [12]. The procedure mentioned requires 5 seconds to complete testing in both the laboratory and field. In a previous report, the BCD was tested to determine the level of accuracy of the device. In this study, the device was tested on the same rubber block eight times. Results of this test concluded that the COV of the strain output for the BCD was 0.5% [19]. In addition, further tests on the actual variability of the individual test results concluded that modulus results varied within 4% or 0.85 MPa of each other [4]. The results of these studies suggested that although the BCD provides timely results, there might be high variability with using the device, which may pose as a concern if used repeatedly in both laboratory and field tests.

Several reports regarding the use of the LWD have revealed that the device produces a wide distribution of results as a result of its poor repeatability. In a previous study, the LWD was utilized for cement-treated clay to monitor the strength gain with time of materials [3]. The results of this study concluded that the LWD yielded unreliable

measurements. Similar observations were made in a study performed using two different LWD models on the same aggregate type [9]. These studies suggested that the LWD might not be capable of reproducing results. In order to determine accurate modulus values of the compacted samples in this study, it is crucial that the device selected could successfully replicate laboratory and field results.

As previously established, the DCP has been used for various geotechnical applications. Operation of the device requires applying an initial seating load onto the area being tested. Many studies have been done in regards to the performance of the DCP. These studies have suggested that the load applied onto the material enhances the consistency of the DCP device [8]. Testing was also performed using the DCP on ten different soil types and locations. Based on the findings of this study, it was reported that the device was capable of replicating accurate testing results. Although specific information on the time required to operate the DCP was not determined, based on the existing literature it can be inferred that the DCP also provides timely results. The previous success of the device in reproducing results in a short amount of time suggested that DCP would be a suitable candidate for this study.

Table 2 below quantifies the repeatability and time for measurement of each device. Included in Table 2 is a ranking of each device based on a scale from 1 to 5; 1 being the most promising of the devices based and 5 being the worst of the devices based on the criteria.

Table 2

Alternative Devices Repeatability and Time Needed for Measurements

Device	Repeatability	Time Needed for Measurements	Rank
GeoGauge	- Variable with non-cohesive, well-graded sands	- Twice as long as NDG	3
PaveTracker	- Testing easily repeatable, but readings are variable - Sensitive with moisture	- Multiple readings needed - Exact time not known	5 (worst)
BCD	- Minimal device variability - Repeatability associated with user placement	- 5 seconds to obtain readings - Rapid testing, but multiple readings recommended	1 (best)
LWD	- Wide scatter and poor repeatability - Especially sensitive with cement-treated clays	- More rapid than NDG - Comparable to DCP	4
DCP	- Applied load remains constant - Variable rest period which is operator dependent	- More rapid than NDG - Comparable to LWD	2

3.2.3 Data Processing and Interpretation Requirements for Alternative Devices

In order to facilitate selecting the appropriate device for additional laboratory and field testing it was necessary to understand how easy/difficult it is to obtain the necessary data following testing using each device. In order to do this, a literature review was conducted on the GeoGauge, PaveTracker, BCD, LWD, and DCP to determine the data processing and interpretation requirements for each device.

According to the device manufacturers, the stiffness and modulus values measured using the GeoGauge can be automatically displayed or stored in the device and downloaded to a computer at a later time [27]. The modulus values obtained are a

function of the materials moisture content and density, while the stiffness measurements are a function of the materials structure. The GeoGauge measures the stiffness of the soil at each frequency and automatically displays an average value. These results can be used to develop relationships between modulus growth and compaction effort in unbound layers [20]. The only drawback to the device is that the load applied to the soil does not represent the actual stress levels encountered in the field, therefore the GeoGauge modulus must be corrected to account for design loads [19]. Despite this minor drawback, the data obtained using the GeoGauge can be easily processed and interpreted.

The PQI and the PaveTracker operate with similar methodologies in that both devices are capable of detecting changes in density throughout a pavement layer. These changes in the density within the layer are attributed to the changes in the electric field caused by the introduction of dielectrics within the layer. Both devices output a direct density reading of the area being tested [24]. Based on previous literature, it can be concluded that both the PQI and the PaveTracker provide direct density measurements without difficulty. In addition, no prior calibrations are needed in order to obtain the results from testing.

The data processing and interpretation of the BCD is simple in that the four electrical strain gauges, attached to the top of the plate, are used to measure the strain values of the soil. The remaining four electrical strain gauges are used for hoop measurements. The load cell above the plate detects the load applied by the operator and a modulus reading is automatically outputted. The soil modulus is then calculated using the bending strains detected by the gauges. A computer processes the bending strains and the modulus of the soil is displayed. It should be noted that the computer automatically

applies pre-calculated field and laboratory calibrations for the device [12] [19]. The literature review conducted on the BCD indicates that both laboratory and field modulus values can be easily outputted from the device.

In order to obtain modulus and stiffness values from the LWD a falling weight is dropped onto the device's loading plate. The impact from the falling weight onto the loading plate causes an impulse load on the compacted material. The resulting deflection values from the loading plate are calculated and are immediately displayed on the device. Assuming an elastic half space medium, the applied surface load and deflection measurements are used to estimate elastic modulus of the tested layer. It is to be noted that studies suggest that no three consecutive modulus values, measured at the same location, should vary by 10%, nor should the number of drops conducted exceed 10 for a single location [9].

Testing using the DCP consists of applying a force onto a pushing rod that drives a cone tip into the soil layer. The device automatically records the number of hammer blows and depth of penetration of the cone. The values obtained from the device can be used to calculate the penetration rate of the cone. It is to be noted that in order to determine the strength of the tested soil using the device necessary correlations must be made between the penetration rate and modulus/strength of the soil [6]. Due to the limitations of the device, if used to determine the compaction quality of pavement layers, several correlations will be required in order to obtain the appropriate values.

Table 3 below ranks the alternative devices data processing and interpretation requirements based on effort, time, and difficulty. It should be noted that a ranking of 1

corresponds to the best device while 5 corresponds to the device associated with the most tedious and difficult data processing and interpretation.

Table 3

Data Processing and Interpretation Requirements for Alternative Devices

Device	Overall Ranking
GeoGauge	2
Non-Nuclear (PaveTracker)	3
BCD	1 (best)
LWD	5 (worst)
DCP	4

3.2.4 Sensitivity of Alternative Devices to Environmental Factors, Accuracy and Ease of Use

Two major attributes were sought out in the devices selected for this study; those included the devices ease of use and accuracy of results. In addition, it was essential that the selected devices could be successfully operated in different environmental conditions. Therefore it was necessary to conduct a literature review on previous studies pertaining to the devices' performance history to determine if the devices met these criteria.

Previous literature has reported many necessary specifications for using the GeoGauge. As mentioned in a previous section, a thin layer of sand must be laid down on the testing location prior to testing. In addition, calibrations must be made to the device for specific materials. In the circumstance that the surface being testing is rough, the sand

applied must be moist to ensure at least 75% contact with the surface. These studies suggested that the positioning and use of the GeoGauge might be difficult depending on the material being tested. Furthermore, the GeoGauge manual stated limitations for the readings obtained using the device. These limitations included: (1) stiffness values in the range of 3 to 70 MN/m, and (2) modulus values in the range of 26.2 to 610 MPa [27]. There are also concerns in regards to the device malfunctioning due to vibrations caused by passing vehicles, such as compaction equipment or trains [23]. These restrictions mentioned may limit the GeoGauge to only certain aggregates and locations, which can make the device very challenging to use in this study.

Previous testing performed using the PQI concluded that the device was problematic when the moisture content within the test area was high. Studies have suggested that moisture levels must remain constant to obtain any type of meaningful data [24]. It can be assumed that since both the PQI and the PaveTracker operate on similar principles, the PaveTracker would most likely experience similar difficulties at high moisture contents. These studies also concluded that the moisture content within the test locations might negatively affect the PQI and PaveTracker results. In addition, as previously mentioned, the procedure for using both devices require multiple readings and prior device calibration, making the devices tedious to operate. The challenges presented indicate that the PQI and PaveTracker might not be suitable devices for additional testing in this study.

The process for operating the BCD is fairly simple in that an appropriate test spot is located, a 50.1-lb. (223-N) load is applied onto the device, and an average modulus value is outputted. The device automatically provides a modulus reading at 50.1-lbs.

(223-N), so if one were to exceed this amount there would be no repercussions. Although the device is easy to operate the device's range for modulus is from 5 to 150 MPa [19]. Previous laboratory studies showed that the BCD could not be used on soils with modulus values below 3 MPa due to bearing capacity failure [12]. In other words, the device sinks into very soft soils under its own weight [19]. In addition, it has been reported that in very stiff soils the bending of the device plate does not adequately measure strains of the soil [19]. Overall, the BCD has been reported easy to use however, the observations mentioned above suggested that the BCD may be limited to specific soils, which may pose as a concern for this study in that four different types of materials are utilized for testing.

Previous studies have suggested that many factors can influence the modulus readings obtained using the LWD. These factors include: (1) falling mass, (2) drop height, (3) plate size and contact stress, (4) type and location of the deflection transducer, (5) usage of load transducer, (6) loading rate, and (7) bugger stiffness. These factors suggest that the LWD might not provide accurate results due to the different types of influences on the device. In addition, previous studies have also reported that the LWD was sensitive to seasonal variations in pavement stiffness on both asphalt and gravel surfaces. In order to ensure a uniform surface, it was recommended that sand be used for the seating of the LWD and that up to 4-inches (10.2-cm) of compacted material be removed prior to testing. It was also recommended that the testing be limited to pavements with a gradient less than 5% [9]. The observations made in past studies suggested that the environmental influences on the LWD might contribute the device's

poor performance. Therefore the LWD may not be suitable for additional testing in this study as the device will be subjected to different types of testing conditions.

The DCP has been reported to be simple and economic, requiring minimum maintenance, providing easy-to-access sites, and continuous measurements of the penetration rate of the sample [6]. Based on the literature provided for the device, it has been suggested that device is relatively easy to use, however, some studies conducted using the DCP have indicated that the values obtained from the DCP are dependent on the conditions in which testing is performed. In a previous study, testing was conducted using the DCP on an asphalt surface, through a hole drilled into the asphalt surface, and on a base layer stripped of its asphalt surface. Based on this study, it was concluded that the results of the device varied between each method. Therefore in order to account for the environmental effects on the device, it was recommended that the DCP test be conducted through a drilled hole [5]. Although minor recommendations for testing have been provided for the DCP, previous studies confirm the devices ease of use if used for this study.

The ranking of the devices are tabulated in Table 4 below. This table illustrates the individual rankings according to the environmental factors, accuracy, and ease of use for each device. The overall rankings were determined by adding up the individual rankings. The devices were ranked from the lowest total (the best device) to the highest total (the worst device). Although the DCP and the GeoGauge were equivalent in overall ranking, the DCP proved to have more established research and ranked the highest in two categories opposed to the GeoGauge which ranked highest in only one category.

Table 4

Sensitivity of Alternative Devices to Environmental Factors, Accuracy, and Ease of Use

Device	Environmental Factors	Accuracy	Ease of Use	Overall Ranking
GeoGauge	3	2	1	2
Non-Nuclear (PaveTracker)	4	4	2	4
BCD	2	3	3	3
LWD	5	5	5	5 (worst)
DCP	1	1	4	1 (best)

3.2.5 Cost of Utilizing Alternative Devices

For the purpose of determining the appropriate devices for additional laboratory and field testing it was necessary to rank the devices according to price. This ranking procedure was developed to facilitate selecting the devices for this study, if the decision was based on the cost of utilizing the devices. The price of each device is tabulated in Table 5 below. It should be noted that the devices for which pricing could not be found are indicated with “N/A” in the table. For the commonly used NDG the price of the device ranges from \$8,000 to \$9,000. The GeoGauge was a fairly expensive device at \$5000-\$5500 according to Mooney et al. [26], or \$6720 according to the device manufacturer Humboldt [27]. Although the GeoGauge is expensive, it is less expensive than the NDG. The cost of the BCD is listed as \$14,065, making the BCD nearly twice as expensive as the NDG. The LWD falls approximately in the same price range as the NDG between \$7,850 and \$8,850. The cheapest device was one of the lower-end DCP models sold by Humboldt at \$545. The most expensive DCP models were listed at \$1620. It is worth noting that during testing it is required to replace the drive cone on the DCP, as the cone may become lost within the sample. According to the device manufacturer

Humboldt [27], each drive cone costs \$32. However, even if the cost of the cones were considered in the price for the most expensive models the DCP still ranks in as the cheapest device. The low cost of the DCP can be attributed to the lack of electronics required to operate the device. Based on the cost of the DCP in conjunction with the previously discussed criteria on the DCP, it can be concluded that the DCP might a suitable device for additional laboratory and field evaluation.

Table 5

Cost of Utilizing Alternative Devices

Device	Cost
GeoGauge	\$6,720
Non-Nuclear (PaveTracker)	N/A
BCD	\$14,065
LWD	\$7,850 - \$8,850
DCP	\$545 - \$1,620

3.2.6 Alternative Devices Ability to Account for Lower Layer Properties

An important factor to consider for the devices selected for this study is the impact of lower layer properties on the devices measurements. In other words, it is necessary to monitor the performance of each device on the test areas to determine if the layers beneath the test location effected the measurements obtained from each device. Based on the evaluation conducted for this criterion, the devices were ranked appropriately.

According to a previous study done, the GeoGauge was reported to measure average modulus values up to 12-inches (30.5-cm) below the surface. In addition, the GeoGauge was particularly sensitive to the top 2-inches (5.1-cm), and the seating procedure required for the device [19] [20]. These results indicated that the GeoGauge was able to account for impacts caused by lower layer properties at the layers closest to the surface. It is to be noted that sufficient information regarding the impacts of lower layer properties on the measurements for the PQI and the PaveTracker could not be determined. According to a study conducted on the BCD, results suggested that device had an influence depth ranging from 4.8 to 12.2-inches (12.2 to 30.9-cm) as the modulus of the material increased from 3 to 300 MPa under large loads [4]. However, the actual influence depth was much smaller under the normal testing load. The results of this study suggest that the BCD is significantly influenced by the surface in which it is testing on; therefore if used for this study the results obtained from the device may contain high variability.

In a previous test conducted, the FWD was tested on an asphalt concrete layer to determine the impact the layer had on the measured results. Based on the results of this study, it was reported that the resilient moduli measured at a layer thickness less than 2.95-inches (7.5-cm) or at shallow bedrock were not accurate. Testing was also performed using the LWD and the results of testing indicated that the device might not be suitable for testing on thicker, stiffer foundations [6]. The conclusions made for the FWD and LWD suggests that if tested on different samples, the thickness of the sample may have an influence on the device's measurements. This would pose a concern for this

study, as the samples prepared for laboratory testing had a thickness of 12-inches (30.5-cm).

Studies have also been conducted to evaluate the ability of the DCP to detect the changes in the layers in which testing was performed on. In a previous study, the DCP was tested on low volume road pavements in order to identify the strength and thickness of different pavement layers of newly constructed roads [28]. The measurements obtained from the DCP were compared with actual on site measurements. It is to be noted that an evaluation of the tests were made for a period of two years and the changes in the penetration resistance for different layers were also measured. Based on the results of this study, it was concluded that the DCP was able to depict the number of pavement layers and thicknesses of each layer. The results measured for the DCP varied within 10% of the actual measurements. The observations made in this study suggest that, if used in this study, the DCP would be able to detect the changes of the samples when compacted at different density levels.

Table 6 below ranks each of the devices based on their ability to account for the impacts of the lower layer properties on their measurements. The effect of the lower layers influenced each device differently. Based on the literature, the DCP was the only device that was capable of accounting for these lower layer properties. Furthermore, the DCP was able to identify these layers as well, thus it was concluded that the DCP was the best device to account for lower layer properties without loss of accuracy. As previously mentioned, the lowest number correlates to the device best able to account for these properties and the highest number corresponds to device least able to account for these properties.

Table 6

Alternative Devices Ability to Account for Lower Layer Properties

Device	Overall Ranking
GeoGauge	2
Non-Nuclear (PaveTracker)	5 (worst)
BCD	3
LWD	4
DCP	1 (best)

3.2.7 Alternative Devices Ability to Correlate Representative Laboratory and Field Moduli

For the purpose of this study, it was necessary that the selected devices could adequately correlate representative laboratory moduli results to field moduli results. In order to determine those that met this requirement a comprehensive literature review was performed on the selected devices. Based on the findings of the literature review, the devices were then ranked according to the success each had with correlating both results.

Based on a previous study field evaluations were conducted to determine the practicality of utilizing the GeoGauge for compaction quality control in pavement construction. Testing was performed on different flexible pavement layers including HMA, base, and subgrade materials during construction. Additional testing was performed upon completion of construction. The results of this study concluded that the GeoGauge was capable of correlating laboratory and field moduli values. In addition, both laboratory and field values were comparable to values obtained through a resilient

modulus regression equation [20]. The observations made in this study suggested that the GeoGauge could successfully correlate laboratory and field moduli results.

Studies have also been performed on the PQI and PaveTracker to determine if these devices could be used to determine the density of HMA pavements. In this study, both devices were utilized for laboratory and field testing. Comparisons were made between the laboratory and field results for both devices to acceptable density values for HMA. Results of this study indicated that the PaveTracker did not correlate well with the measured core densities. The density readings obtained by the PaveTracker were statistically different from the core densities in 68% of the projects cited [24]. It was also reported that the PQI did not correlate well with measured core densities in that the density values obtained using the device were statistically different in 54% of those projects. Based on the observations made in this study it can be suggested that both the PaveTracker along with the PQI could not effectively correlate between representative laboratory and field moduli.

In order to validate the use of the BCD for compaction quality control in pavement construction several studies have been performed using the device. As previously discussed, a series of field tests were conducted using the BCD on six different soil types and pavement bases [12]. Testing was also done on the same locations using the PLT. In order to determine if the BCD accurately captured the modulus values of these pavement layers, laboratory testing was conducted on prepared soil aggregate samples. The field results obtained using the BCD were then compared to the PLT and laboratory results. The results of this study indicated that both laboratory and field moduli could successful be correlated to one another using the BCD.

Throughout literature, multiple tests have been performed using the DCP to validate the use of the device for measuring the modulus of pavement layers. The results of these tests have been correlated to field moduli values measured using different non-nuclear devices. Specifically, in a past study, DCP field and laboratory tests were conducted in conjunction with the PLT. Results of these tests were then compared to field results obtained using the FWD and to laboratory CBR test results [6]. The results of the regression analysis discovered that the models developed for the DCP could successfully predict the measured FWD results with a R-squared equal to 0.91 for both devices. In addition, it was also observed that the results from the DCP tests correlated well with the CBR values. The conclusions made through this study suggested that the DCP could adequately evaluate the stiffness and strength of pavement layers if used for further evaluation.

Table 7 below displays the ranking of how well each device performed with correlating representative laboratory and field moduli results. The highest ranking corresponded to the device that best correlated between laboratory and field moduli. The devices with the lowest ranking represented those that poorly correlated these values.

Table 7

Alternative Devices Ability to Correlate Representative Laboratory and Field Moduli

Device	Overall Ranking
GeoGauge	3
Non-Nuclear (PaveTracker)	5 (worst)
BCD	1 (best)
LWD	4
DCP	2

3.2.8 Alternative Devices Ability to Account for Field Moisture and Density Variability

One of the main objectives developed for this study was to evaluate the NDG and selected devices on their ability to account for different moisture contents and density levels. In order to determine the sensitivity of the devices to these two factors a literature review was conducted on the devices past performances. Based on the results of the literature review the devices were then ranked according to their ability to account for field moisture and density variability.

As previously mentioned, a study was conducted using the GeoGauge on different dry sand and cohesion soil materials. Testing was performed on these materials to determine if the GeoGauge measurements were consistent with soil mechanics concepts. Based on the results of this study it was concluded that the stiffness measured from the device decreased as the moisture content increased [2]. In addition, it was suggested that the GeoGauge be calibrated prior to testing in order to account for moisture content. The results of this study suggest that the GeoGauge is moisture sensitive and can detect the

changes in the moisture within the tested area. Therefore, if used for additional laboratory evaluation, the device could effectively account for the moisture variability between the samples.

A study was conducted to evaluate if the PQI could be used to determine the density of HMA pavements. In this study comparisons were made between laboratory and acceptable density values of HMA and density values obtained from the PQI. The laboratory tests conducted indicated that the PQI could detect changes in density of the HMA for a single asphalt mixture. However, the device could not accurately detect density when tested in the field. In addition, the PQI proved to be problematic when operated at high moisture contents. In order to obtain meaningful data, the moisture level of the tested area must remain constant [24]. Based on these observations, it was suggested that if used for field testing the device would require certain correction factors to correct for moisture and density variability.

It is to be noted that information regarding the impact of field moisture and density variability could not be obtained for the PaveTracker. Based on the similar operating principles, it can be assumed that a correlation can be made between the PQI and the PaveTracker. Based on this assumption, it can be concluded that both the PQI and PaveTracker both perform poorly when exposed to high levels of moisture within a sample, therefore both may not be suitable for testing in this study.

Previous laboratory testing was conducted to evaluate the impact of moisture and dry density on the results obtained using the BCD. In this study a series of compaction tests were performed on laboratory prepared samples. The samples were prepared at varying moisture contents in order to compare the variability of BCD modulus with

moisture content and dry density. The results of this study indicated that the measured modulus was 75% of the maximum. In addition, the BCD was more sensitive to moisture content than to dry density [12]. Overall, this study suggests that the BCD is sensitive to changes in moisture content and dry density; therefore it would be suitable for additional testing in this study.

As previously established, the LWD is sensitive to cement-treated clay materials [3]. This sensitivity was directly linked to the lack of moisture within the material. In other words, the lack of moisture affected the strength gain with time for cement-treated clays and caused shrinkage cracks near the surface of the material. These surface cracks significantly affect the results of the LWD measurements. In addition, the LWD was also sensitive to field moisture and density variability (i.e. void ratio changes) in which calibration curves were necessary for accurate readings. Similar to the BCD results previously discussed, it is concluded that the LWD was also sensitive to changes in aggregate moisture content and density.

Based on previous literature, the DCP test results were influenced by the moisture content, dry unit weight, and soil type. The DPI increases with the increase in moisture content and it decreases with the increase in dry unit weight. The resilient modulus was also influenced by the moisture content, dry unit weight, and soil type in that the resilient modulus decreases with the increase in moisture content and it increases with the increase in dry unit weight [8]. Based on the previous studies conducted using this device, it is evident that the DCP is capable of detecting changes in the moisture and density within the tested area. These capabilities of the DCP are crucial for the devices selected for evaluation in this study.

Table 8 below ranks each of the devices based on ability to account for the impacts of field moisture and density variability on measured moduli. As previously mentioned, the lowest number correlates to the device best able to account for these properties and the highest number corresponds to the least able device. It should be noted that all devices are sensitive to moisture content, thus the ultimate ranking was dependent on the devices' means to account for varying moisture contents. Likewise, devices also sensitive to variable density received a lower ranking.

Table 8

Alternative Devices Ability to Account for Field Moisture and Density Variability

Device	Overall Ranking
GeoGauge	1 (best)
Non-Nuclear (PaveTracker)	5 (worst)
BCD	2
LWD	4
DCP	3

3.2.9 Sensitivity of Alternative Devices to Various Levels of Compaction

As part of this study, one of the objectives developed was to evaluate the effect of different compaction efforts on the testing results obtained from the NDG and selected non-nuclear devices. Therefore, a literature review was conducted on the sensitivity of the devices to various levels of compaction. Based on previous studies the devices were than ranked accordingly.

To account for the variability of compaction over short distances, it is suggested that multiple measurements be taken using the GeoGauge. The data collected can then be averaged together to obtain one measurement. In addition, it is suggested that measurements using the GeoGauge be obtained in increments of 2-feet (0.6-m) or less, at locations in a straight line of one another. In addition, oversampling was suggested as a result of the variability in the compaction of the sample over short distances [27]. Based on the previous studies done using the GeoGauge, it can be seen that there are many recommendations for using the device in order to account for the variability in compaction. Therefore it can be concluded that the device is sensitive to different levels of compaction and if used in this study, the device will be capable of detecting changes in the density of the compacted samples. It is to be noted that sufficient information regarding the sensitivity of the PaveTracker, BCD, and LWD to various levels of compaction could not be determined.

Through a comprehensive literature review it is evident that the DCP is also sensitive to various levels of compaction. Previous studies reported the wear and tear of the DCP cones used to penetrate the test area when repeatedly exposed to stiff materials. This suggests that the DCP is capable of detected different levels of compaction. In addition, previous literature discusses properly compacted granular base materials having uniform penetration rate values. Furthermore, for lightly compacted materials the DCP penetrate rates were higher. These results suggest that DCP was able to detect the increase in strength and stiffness of the material as a result of compaction [27]. Based on these studies, it is evident that the DCP has the ability to verify both the level and

uniformity of compaction, making it a suitable device for additional laboratory and field evaluation.

Table 9 below ranks each of the devices based on sensitivity of the device to various levels of compaction. Devices that did contain sufficient information received a ranking of 5 because, as previously stated, the lowest number correlates to the device most sensitive to account for these properties and the highest number corresponds to the least sensitive device.

Table 9

Sensitivity of Alternative Devices to Various Levels of Compaction

Device	Overall Ranking
GeoGauge	2
Non-Nuclear (PaveTracker)	5 (worst)
BCD	4
LWD	3
DCP	1 (best)

3.2.10 Overall Ranking of Alternative Devices

The overall ranking of each device per criteria is presented in Tables 10 and 11 below. Table 10 presents the evaluation of each alternative device based on all criteria, including the cost to utilize each device. Table 11 presents the same results, however this evaluation eliminates the cost criteria. This was done in order to rank the devices based on performance alone, if money was not a concern.

Table 10

Evaluation of Alternative Devices Based on all Criteria

Device	Criteria									Overall Ranking
	One	Two	Three	Four	Five	Six	Seven	Eight	Nine	
GeoGauge	3	3	2	2	2	2	3	1	2	2
Non-Nuclear (PaveTracker)	5	5	3	4	5	5	5	5	5	5 (worst)
BCD	2	1	1	3	4	3	1	2	5	3
LWD	4	4	5	5	3	4	4	4	3	4
DCP	1	2	4	1	1	1	2	3	1	1 (best)

Table 11

Evaluation of Alternative Devices Based on Non-Cost Criteria

Device	Criteria									Overall Ranking
	One	Two	Three	Four	Five	Six	Seven	Eight	Nine	
GeoGauge	3	3	2	2	--	2	3	1	2	2 (tie)
Non-Nuclear (PaveTracker)	5	5	3	4	--	5	5	5	5	5 (worst)
BCD	2	1	1	3	--	3	1	2	5	2 (tie)
LWD	4	4	5	5	--	4	4	4	3	4
DCP	1	2	4	1	--	1	2	3	1	1 (best)

3.3 Survey of State DOTs, Contractors and Manufacturers

In order to obtain the most recent feedback on the alternative devices and opinions on transiting from density-based testing and towards modulus/stiffness-based methods a survey was developed for this study. Prior to this thesis, the National Cooperative Highway Research Program (NCHRP) released a substantial report on alternatives to the NDG. Based on the results, it was reported that most state DOT agencies still employ the NDG as their primary tool for the acceptance of unbound subgrade and base/subbase layers. However, the study also reported that 44% of agencies said they would move to a non-nuclear device and modulus-based quality control method

because a nuclear certification was too inconvenient. Of the same group, 41% said certification was also too expensive. 37% of this group mentioned safety concerns as reasons for transitioning to modulus-based quality control. Based on the responses of the NCHRP report, a set of survey questions was developed. The survey prepared for this study can be found in Appendix A.

The survey presented in this chapter was developed using SurveyMonkey and was sent out to state DOTs in Indiana, Iowa, Illinois, Louisiana, Minnesota, Missouri, and Texas. In addition, the survey was sent to local (i.e., New Jersey) and national contractors/manufacturers. The objectives of this survey included:

- Determine the problems and concerns of using nuclear and non-nuclear devices in highway construction;
- Identify if other non-nuclear devices or modulus-based specifications are currently used/considered for the near future;
- Identify technical and institutional issues that may lead to abandoning quality acceptance based on nuclear methods; and
- Determining existing difficulties of using non-nuclear devices or challenges transitioning to another acceptance methodology.

Unfortunately, only three responses were obtained from the developed survey. The responses from the three respondents are presented in this section. Initially, state DOT engineers were asked for their opinions on the factors that attributed to the popularity of the NDG as a tool for compaction quality control. There was a general agreement among the three respondents that NDG results were timely and easy to analyze

and interpret. The second set of questions was to gauge the respondents' views on the drawbacks of the NDG. The two major drawbacks all respondents agreed on were (1) the requirements for specialized/isolated storage, and (2) density measurements as opposed to strength/modulus parameters. The drawbacks provided by the three respondents were consistent with the major concerns, previously established in literature, with using the NDG.

Survey respondents were then asked to rank the desired attributes sought out in alternative devices. This ranking was based on a scale from 1-not important at all to 6-extremely important. The responses are displayed in Table 12 below. The most essential attributes that gained the highest ranking were repeatability and time needed for measurements. In addition to the specific attributes surveyed, the respondents were given a chance to provide an additional set of attributes they would like to have in an alternative device. The attributes that the respondents mentioned were (1) devices that require simple training to conduct testing, (2) devices that are simple and easily understood, and (3) devices with no licensing requirements.

Table 12

Surveyor Ranking of Alternative Device Attributes

Attribute	Respondent Number 1	Respondent Number 2	Respondent Number 3	Total Ranking
Repeatability of measurements	6 ²	6	6	12
Time for measurements	5	5	3	10
Ease of data processing	2	4	4	6
Sensitivity to environmental factors	3	2	1	5
Ease of use and accuracy	4	3	5	7
Cost	1 ¹	1	2	2

¹ not important² extremely important

The three surveyors were then asked to provide opinions on the attributes of the major alternative devices identified through the literature review. These devices included the GeoGauge, PaveTracker, BCD, LWD, and DCP. The respondents were given the option to skip questions regarding a specific device if they did not have prior knowledge of the device. Unfortunately, all three respondents only had knowledge of the GeoGauge and DCP. The results are listed in Tables 13 and 14 below.

The respondents were allowed to provide additional comments on both devices. However, no comments were made for the GeoGauge. As for the DCP, respondents mentioned that the device was easy to use, and did not require supervision during testing. In addition, testing could be conducted at a later time and that the device was a good diagnostic tool.

The disadvantage of using the DCP, as the respondents listed, was that the device is sensitive to moisture. The results obtained through the provided survey were consistent

with the literature review in that both the GeoGauge and DCP were practical devices and might be suitable alternatives to the NDG.

Table 13

Surveyor Opinions on the GeoGauge

Attribute	Respondent Number 1	Respondent Number 2	Respondent Number 3
Accuracy & repeatability of measurements	Disagree	Neutral	Disagree
Ease of analysis and interpretation of results	Disagree	Neutral	Agree
Output obtained in a timely manner	Disagree	Agree	Agree
Portability of the device	Neutral	Agree	Agree
Influence of environmental factors	Neutral	Neutral	Disagree
Influence of lower layer properties	Neutral	Disagree	Neutral
Readings are representative of field	Neutral	Neutral	Neutral
Cost of device	Neutral	Neutral	Disagree

Table 14

Surveyor Opinions on the DCP

Attribute	Respondent Number 1	Respondent Number 2	Respondent Number 3
Accuracy & repeatability of measurements	Strongly Agree	Agree	Disagree
Ease of analysis and interpretation of results	Strongly Agree	Strongly Agree	Disagree
Output obtained in a timely manner	Strongly Agree	Strongly Agree	Agree
Portability of the device	Strongly Agree	Strongly Agree	Agree
Influence of environmental factors	Strongly Agree	Disagree	Neutral
Influence of lower layer properties	Neutral	Agree	Neutral
Readings are representative of field	Strongly Agree	Strongly Agree	Agree
Cost of device	Strongly Agree	Strongly Agree	Disagree

Once the respondents provided their opinions on the GeoGauge, PaveTracker, BCD, LWD, and DCP they were then asked to rank these devices on a scale of 1-being an excellent alternative to the NDG to 5-being a very poor alternative to the NDG. It is to be noted that “N/A” was listed for the respondents who had no prior experience/knowledge with a particular device. The overall ranking of the alternative devices is displayed in Table 15 below. Consistent with the previously literature review the DCP achieved the highest ranking out of all the devices.

Table 15

Overall Surveyor Ranking of Alternative Devices

Alternative Device/Method	Respondent Number 1	Respondent Number 2	Respondent Number 3
GeoGauge	4	3	2
Non-Nuclear (PaveTracker)	4	5	N/A
BCD	4	4	4
LWD	4	2	4
DCP	1	1	2
Others	N/A	N/A	N/A

The final segment of the survey asked the respondents to provide their opinion on transitioning to non-nuclear alternative device and the factors that may hinder the implementation of a new device. The results obtained from the three respondents are displayed in Table 16 below.

Table 16

Surveyor Opinions on Transitioning

Question	Respondent Number 1	Respondent Number 2	Respondent Number 3
Agencies interest in strength/stiffness device	Moderate	Substantial	Extremely
Agencies interest in implementing	Moderate	Substantial	Extremely
Possibility of transitioning	Maybe	No	Yes

From the results obtained through the survey, the respondents displayed an interest in transitioning to an alternative device. However, all respondents commented on factors that may hinder the possibility of transitioning towards an alternative non-nuclear device. Respondents mentioned that a lack of familiarity as well as trained personnel with the new device would keep agencies from transitioning. Furthermore, the devices sensitivity to moisture poses as a major concern in transitioning.

Based on the literature review conducted in this study and the survey sent to state DOT materials engineers, device manufacturers, and contractors, three devices were selected for further investigation as an alternative to the NDG. The devices selected for further laboratory and field assessment were the BCD, LWD, and DCP.

3.4 Description of Selected Devices

3.4.1 Briaud Compaction Device (BCD)

The BCD is a recently developed device and is a paid tester of soil modulus bear the ground surface. The device is named after its inventor, Jean-Louis Briaud, F.ASCE of Texas A&M University. Jen-Louis Briaud successfully developed the first prototype in

2003, with the assistance of manufacturer Roctest. The device went through three additional revisions before ultimately becoming a portable device sold by Roctest in 2007 [29].

The BCD consists of a 6-inch (15.2-cm) diameter flexible plate retrofitted with eight radial and axial strain gauges, located at the bottom end of a rod. To operate the device it is first placed on top of the layer being tested. The operator then gradually applies a load of 50-lb. (222.4-N) magnitude onto the device handles. The flexible plate, at the bottom of the rod, then measures the plate's deformation as the load is applied onto the device. Higher deformation values, measured by the device, usually indicate lower modulus values for the compacted soil. According to the device manufacturer, it is recommended that four measurements be taken 90° apart at one testing location for a better reading [12]. The collected measurements are then automatically stored for retrieval at a later time. A schematic of the BCD is shown in Figure 1 and a final prototype of the BCD is illustrated in Figure 2 below.

The concept behind the device is simple in that the stiffer the soil is the less the plate will bend and vice versa for softer soils. Therefore, the strain measurements of the plate are directly related to the modulus of the soil beneath the device. All necessary corresponding calibrations are done internally within the device [12].

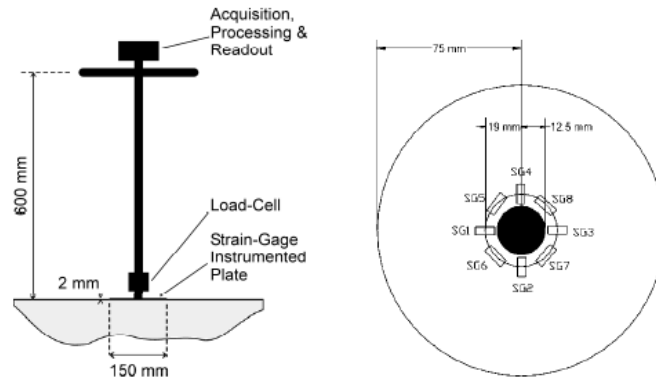

Figure 1. Initial BCD with Corresponding Plan View of Plate [12]



Figure 2. Final Prototype of BCD [12]

3.4.2 Light Weight Falling Deflectometer (LWD)

The LWD is a portable device utilized to determine the dynamic modulus of compacted aggregate layers. The LWD was first developed in Germany and has been

utilized during the construction of pavement foundations [10]. Due to its portability and potential for estimating fundamental material properties, the LWD has gained much attention for quality control during pavement construction. One of the most popular LWDs is the Prima 100, developed by Carl Bro Pavement Consultants in Kolding, Denmark. The LWD is operated under the ASTM E2583-07 specification [19]. The procedure for using the LWD requires applying three seating loads onto a 7.8-inch (19.8-cm) bearing plate using a standard weight of 22-lbs. (9.9-kg). Following the required seating blows, a final dynamic load is applied freely onto the plate. The bearing plate, containing geophone sensors, then measure the aggregate layer's dynamic deflection modulus caused by the impact of the falling weight. The device automatically outputs and stores the measured deflection values. The measured deflection at the center of the plate is then used to calculate the dynamic deformation modulus E_{LFWD} using Boussinesq equation as follows:

$$E_{LFWD} = \frac{k(1-\nu^2)\sigma R}{\delta_c}$$

Equation 1

Where:

E_{LFWD} = Dynamic deformation modulus

$k = \pi/2$ for rigid and 2 for flexible plates

ν = Poisson's ratio, (default value of 0.35)

σ = Applied stress

R = Radius of the plate

δ_c = Center deflection

3.4.3 Dynamic Cone Penetrometer (DCP)

Initially developed in South Africa for in-situ evaluation of pavements, the DCP has been recently implemented in South Africa, United Kingdom, Australia, New Zealand, and several states in the United States, specifically the U.S. Army Corps of Engineers, for characterization of pavement layers and subgrades [6]. The device consists of a 22.6-inch (57.5-cm) upper fixed rod with a 17.6-lb. (8-kg) falling mass. At the bottom of the device is a lower 0.63-inch (16-mm) diameter rod containing an anvil and 0.79-inch (20-mm) diameter steel cone with an apex angle of 60 degrees [6]. A schematic of the device can be seen in Figure 3 below. The DCP test is conducted according to ASTM D6951 or ASTM D7380 standards. The DCP requires two operators, one for lifting and dropping the hammer and one for measuring and recording the penetration depth for each blow [8].

Operation of the device requires dropping the standard hammer weight of 17.6-lbs. (17.9-kg) from a height of 22.6-inches (57.4-cm) onto the anvil attached to the top of a pushing rod. The force from the weight onto the pushing rod then drives the cone tip into the soil layer. The device then records the number of hammer blows and the depth of penetration into the soil. The number of blows recorded can be plotted against depth to obtain the penetration rate (mm/blow), which can then be calculated and correlated to the modulus and strength of the tested pavement sections [6]. The DCP results are usually normalized with penetration depth. Therefore, it can be hypothesized that the higher number of blows required to penetrate 12-inches (30.5-cm) of soil, the better the compaction applied is. The DCP utilized in this study was retrofitted with an automatic

ruler that recorded and stored the penetrated depth and number of blows applied to the samples.

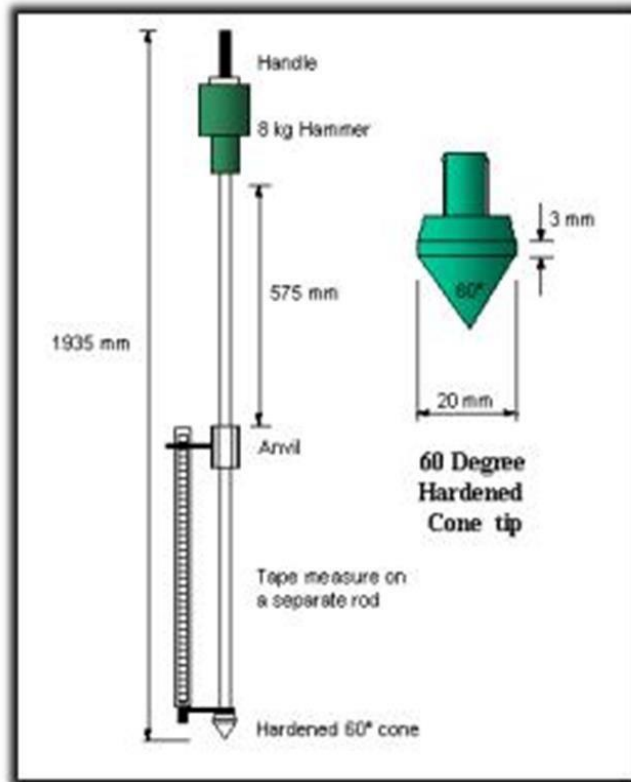

Figure 3. Schematic of the DCP [6]

Chapter 4

Materials Description

4.1 Introduction

This chapter discusses the four aggregate types that were utilized to facilitate laboratory and field testing. In addition, this chapter presents the material properties determined for each aggregate. The aggregates selected for this study included two subgrade soils, natural sand 1 (NAT-1) and natural sand 2 (NAT-2), as well as two base/subbase materials, dense graded aggregate (DGA) with RAP and recycled concrete aggregate (RCA). The different aggregate types selected for this study were necessary for evaluating the impact of aggregate type on the testing results obtained from the non-nuclear devices and the NDG.

4.2 Material Properties

4.2.1 Gradation

Upon collecting the material, testing was conducted to determine the particle size distribution (PSD) of the selected aggregates. Figure 4 below presents the PSD for NAT-1, NAT-2, DGA, and RCA materials respectively. As can be seen from this figure, both subgrade soils (NAT-1 and NAT-2) can be classified as gap-graded while both base/subbase materials (DGA and RCA) had a well-graded gradation. It can also be observed from Figure 4 that both DGA and RCA materials had lower percent passing values at large sieve openings when compared to percent passing values for both NAT-1 and NAT-2 at the equivalent sizes. This suggests that the base/subbase aggregates had a

higher percentage of coarse materials (i.e., having a size larger than a No. 4 sieve opening) than did both subgrade aggregates. In addition, all four aggregates did not have a significant amount of very fine materials (passing sieve No. 200).

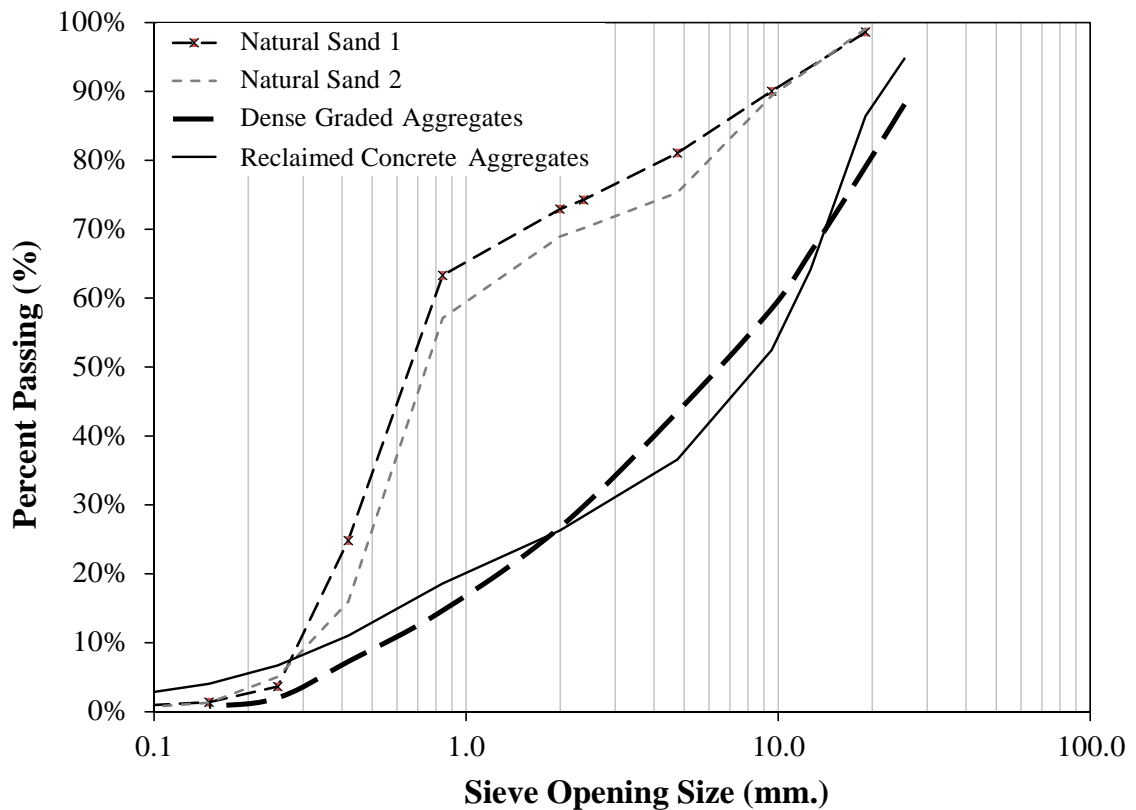

Figure 4. Particle Size Distributions Obtained for Selected Aggregates

4.2.2 Moisture-Density Relationship

The moisture-density relationship for each material was determined in accordance to the modified Proctor test [30]. NAT-1 and NAT-2 materials were first separated into two groups: (1) material passing the No 4 sieve, and (2) materials retained on the No. 4

sieve. Using the material passing the No. 4 sieve, five samples were prepared at different moisture contents. The moisture contents selected ranged from 5 to 15% by weight of dry mass. For each of the samples, the material was placed in a 4-inch (10.2-cm) diameter compaction mold using a five-layer scheme. Each layer was then subjected to 25 blows using a compaction hammer. Similar procedures were utilized for both base/subbase materials (DGA and RCA), however the materials were initially separated into two groups: (1) larger than $\frac{3}{4}$ -inch and (2) smaller than $\frac{3}{4}$ -inch. Samples were prepared using the materials smaller than $\frac{3}{4}$ -inch in a similar five-layer scheme. However, each layer was subject to 54 blows using the compaction hammer. Figure 5 below presents the moisture-density relationships obtained for all selected aggregates. Testing using the Proctor test yielded an average OMC of 9.7% and MDD of 110 lbs./ft.³ for NAT-1. An OMC of 9.65% and MDD of 120 lbs./ft.³ were obtained for NAT-2. DGA material had an average of 8.7% OMC achieving a MDD of 125 lbs./ft.³. The RCA had an OMC of 10.7% and MDD of 138 lbs./ft.³.

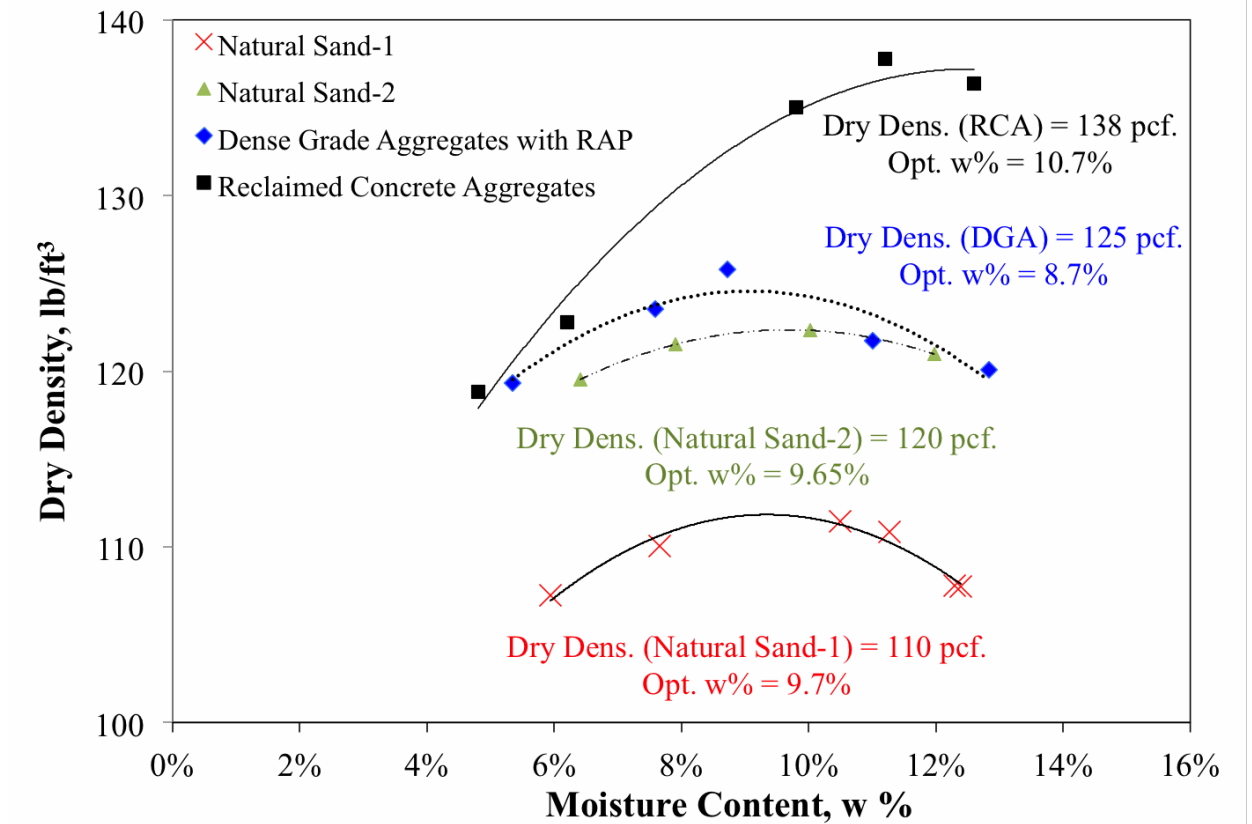

Figure 5. Moisture-Density Relationships for Selected Aggregates

Chapter 5

Laboratory Sample Preparation & Testing Methodology

5.1 Introduction

This chapter includes a description of the sample preparation procedure developed for laboratory testing. In addition, the laboratory testing plan prepared to evaluate the effect of different measured parameters on the testing results obtained from the NDG and selected non-nuclear devices are discussed in detail. These measured parameters include: (1) moisture content, (2) compaction effort applied, (3) aggregate type, and (4) delayed testing. The laboratory facility utilized to conduct testing on the selected devices was located at Advanced Infrastructure Design (AID) in Trenton, New Jersey. In addition, the sections selected for field testing are also presented in this chapter.

5.2 Laboratory Sample Preparation Procedure

In order to evaluate the effect of aggregate type, moisture content, compaction effort, and delayed testing on the results obtained from the NDG and the other three selected devices it was necessary to develop a laboratory compaction procedure for preparing large aggregate samples. The compaction procedure established allowed the different test results to be compared when the moisture content, compaction efforts, and aggregate types were varied between samples. It is to be noted that the Proctor moisture-density relationships (discussed in the previous chapter) were utilized when determining the appropriate moisture and density levels required for preparing each sample. A detailed description of the step-by-step laboratory sample compaction procedure performed is presented in the following subsections.

5.2.1 Drying of Selected Aggregates

Prior to compacting the aggregate samples, it was necessary to air-dry the material being used. Depending on the amount of samples being prepared at the time, the aggregates were spread onto an open floor within the laboratory. It is to be mentioned that two samples required roughly 1,000-lbs. (453.6-kg) of material to completely fill both molds. The aggregates were then air-dried under ambient temperature for about a week. The aggregates were periodically raked throughout the week to ensure the material was uniformly dried. This raking method was also performed to confirm that the moisture content within the aggregates was lower than the moisture content being targeted for that sample.

5.2.2 Determined Moisture Content of Aggregates

Upon completion of drying the material, the required moisture content for the aggregates was calculated. This was completed by first collecting moisture samples from the air-dried aggregates. Depending on the amount of material being dried, typically five to six samples were collected to determine the existing moisture content of the aggregates. It is worth mentioning that these samples were taken at random throughout the material to ensure that an average moisture content was being computed. The weights of the moist aggregates were measured and the samples were dried in an oven that was preheated to 300°F.

After an hour of drying, the samples were then removed from the oven and the weights of the dried aggregates were measured. Based on the dry weights determined for each sample, an average moisture content was computed for the material. This average

moisture content was used in determining the amount of water needed to reach the targeted moisture content for the aggregates. As an example, if the targeted moisture content of NAT-1 was 9.7% and the existing moisture of the material was 2% then roughly 7.7-lbs. (3.5-kg) of water was required for every 100-lbs. (45.4-kg) of material used. It was crucial to calculate the amount of water needed to reach the target moisture content to ensure that the molds were prepared at the appropriate moisture content and not at moisture contents significantly below/above the target. In addition, the determined amount of water required for every 100-lbs. (45.4-kg) of material was utilized during the mixing and placement of the aggregates to be discussed in the following subsection. An average moisture content was determined for all the aggregates prepared in this study.

5.2.3 Mixing and Placement of Aggregates

Once the amount of water required to reach the targeted moisture content was determined, the water was mixed with the air-dried aggregates. The aggregates were mixed for five minutes using a concrete mixer to ensure that the water was uniformly distributed within the aggregates.

Using a mallet, blows were repeatedly applied to the sides of the mixer to ensure that the material did not adhere to the inside walls during mixing. The concrete mixer utilized for this study is illustrated in Figure 6a below.

Once the aggregates were mixed with the required amount of water, the aggregates were then weighed and placed into the mold. Depending on the material and quantity of water used for each material, each lift required approximately 100 to 130-lbs.

(45.4 to 58.9-kg) of dry aggregates. Additional information regarding the weight of each lift is discussed in the following subsection.

The mixing procedure described in this section was performed three times for each sample. This was done in order to place the aggregate in three consecutive 4-inch (10.2-cm) thick lifts. Moisture samples were taken between each mixing process to confirm that the targeted moisture content was reached for each lift.

5.2.4 Compaction of Aggregates

Each sample prepared for this study was prepared in a large aluminum mold that was 24-inches (60.9-cm) in length, 17-inches (43.2-cm) wide, and 12-inches (30.5-cm) deep. An illustration of the aluminum molds used for the samples is presented in Figure 6c below. As previously mentioned, the aggregates were placed in three 4-inch (10.2-cm) thick lifts. Depending on the parameter being evaluated (i.e., moisture content or compaction effort) the amount of aggregates needed for each lift was determined based on three factors: (1) the aggregate moisture-density relationship, (2) mold and lift dimensions, and (3) targeted moisture content/density level. For example, if the targeted moisture content for the material was the OMC then the proctor MDD and volume of the mold (2.82 ft³) was utilized for calculating the required weight per lift using the known density-mass-volume relationship.

Similarly, this procedure was implemented for samples at varying compaction efforts; however density values significantly higher/lower than the MDD were selected and used for computing the required lift weights. As an example, if the targeted density for NAT-1 was below MDD (112 lbs./ft.³) then 105 lbs./ft.³ was used to calculate the

necessary lift weight. The density values selected for these samples are discussed in the following chapter.

Once the required lift weights were determined, the aggregates were weighed and placed into the aluminum molds. A manual steel tamper was used to compact the samples prepared at OMC and above/below OMC. It is to be noted that for samples prepared at higher/lower compaction effort either a manual steel tamper or jackhammer was used. Figure 6b below illustrates the steel tamper used to compact the samples. Once each lift reached a thickness of 4-inches (10.2-cm) the compaction process was deemed complete. This process was repeated two additional times to completely fill the 12-inch (30.5-cm) thick mold with aggregates.

5.2.5 Verified Compaction Quality

The moisture content and density values measured before and after the compaction process was used to verify the quality of the compaction procedure implemented for the aggregate samples. As mentioned previously, throughout the mixing process, moisture samples were collected for each lift. These samples were used to confirm whether the targeted moisture content was reached for each mold. Based on the moisture samples collected for each lift, an average moisture content was calculated and the results were compared to the targeted moisture content. Based on these results, it was observed that the actual moisture contents measured were within $\pm 0.5\%$ of the targeted moisture content.

In addition, following compaction, testing was conducted on each sample using the NDG. The density values measured using the NDG were used to verify whether the

targeted density was achieved. This was achieved by comparing the density values obtained from the NDG to the density values calculated using the three lift weights and mold volume. The comparison between these values confirmed that the density of samples were within ± 5 lbs./ft.³ of the targeted value for all aggregate types. Based on the analysis conducted, it was confirmed that the aggregate samples prepared for laboratory testing were adequately compacted.



(a)



(b)



(c)

Figure 6. Equipment Used for Sample Preparation;
(a) Concrete Mixer, (b) Compaction Steel Tamper; and (c) Sample Mold

5.3 Laboratory Testing Plan

5.3.1 Effect of Moisture Content

In order to evaluate the effect of moisture content on the testing results obtained from the NDG and non-nuclear devices three moisture levels were selected. These moisture contents included the OMC, 2% higher than OMC, and 2% lower than OMC. The corresponding densities for each aggregate, as previously determined using the Proctor moisture-density relationships, were then used to determine the weight required for each lift during the mold compaction procedure to be discussed in the following section. For each aggregate type two large samples were compacted for all moisture contents. It should be noted that, in order to account for any possible variability in the testing results, two samples were prepared for each aggregate type and averaged together to obtain one measurement. The compacted samples were then tested using the NDG, BCD, LWD, and DCP devices immediately (i.e., within 1 hour) after compaction, 24 hours after compaction, and 48 hours after completion of compaction. This testing scheme was implemented to evaluate the effect of delayed testing on the results collected from these devices. Table 17 below presents the moisture contents selected for evaluated for the NAT-1, NAT-2, DGA, and RCA materials respectively.

5.3.2 Effect of Compaction Effort

In order to evaluate the impact of different compaction efforts on testing results obtained from the NDG and non-nuclear devices three density levels were selected for the compacted samples. It is to be noted that all samples compacted to evaluate the effect of compaction effort were kept at constant moisture content (i.e., the OMC). Initially, the

Proctor test moisture-density relationships were developed using higher/lower compaction efforts (i.e., 50% higher/lower blows than standard number of blows) to obtain the density value needed to prepare samples at higher/lower compaction efforts. However, these relationships yielded densities that were within ± 5 lbs./ft.³ of the values determined using the Proctor standard number of blows. To ensure truly applying distinctive compaction efforts, density levels were selected based on the density results obtained through testing at the Proctor MDD rather than using higher/lower compaction efforts. The densities selected for testing included the Proctor MDD, 5 to 20 lbs./ft.³ higher than MDD, and 5 to 15 lbs./ft.³ lower than MDD. The specific density values used to evaluate the effect of compaction effort on the testing results for each material are also presented in Table 17 below.

Table 17

Target Moisture and Density Values Utilized for Compacting the Selected Aggregate Types

Experiment	Level Tested	NAT-1	NAT-2	DGA	RCA
Effect of Moisture Content (%)	2% Below OMC	7.7	7.7	6.7	8.7
	Opt. Moist. Cont.	9.7	9.7	8.7	10.7
	2% Above OMC	11.7	11.7	10.7	12.7
Effect of Compaction Effort* (lbs./ft. ³)	Below MDD	105	105	115	115
	Max. Dry Density	112	120	125	125
	Above MDD	120	135	145	130

* Moisture contents were kept constant at OMC.

5.4 Field Testing Plan

5.4.1 Selected Field Sections

In addition to laboratory prepared samples, the testing plan prepared for this study involved evaluating field-compacted unbound subgrade and base/subbase layers using the NDG and non-nuclear devices. For the purpose of this study, three 100-ft (30.5-m) long field sections were selected for testing.

The first two 100-ft (30.5-m) long sections were located at the Route 35 Restoration Project located in the boroughs of Mantaloking, Lavalette and Ocean Beach, New Jersey. Testing was conducted on the stretch from milepost 4.0 – 9.5. The two 100-ft (30.5-m) long sections consisted of a compacted NAT-1 soil layer overlaid with a compacted DGA layer. It should be noted that the first 100-ft (30.5-m) section located along 6th Ave was tested immediately following fine grading, 24 hours, and 48 hours after preparation. The second 100-ft (30.5-m) long section was tested prior to compaction, immediately after preparation, 24 hours, and 48 hours after. Reference densities of 143.7 lbs./ft³ and 123.7 lbs./ft³ for both sections were provided on site.

The third field section was located at Interstate 295 at the divide between I-295 and I-76 in Haddon Heights, New Jersey. The third section consisted of a NAT-2 subgrade layer overlaid with an RCA base layer. Around 30 points within each field section were evaluated using the NDG and non-nuclear devices. It is worth mentioning that due to the limitations of construction all field sections were tested at constant moisture content. In addition, moisture content samples were only collected for the first two field sections.

Chapter 6

Analysis of Laboratory Testing Results

6.1 Introduction

This chapter presents the results collected for the samples compacted at different moisture contents and density levels. The effect of moisture content, compaction effort, delayed testing, and aggregate type on the test results measured using the NDG and non-nuclear devices are also discussed in this chapter. This chapter also presents the results of a multi-factor analysis of variance (MANOVA) conducted to evaluate the significance of these factors on the NDG and selected devices. It is worth mentioning that this analysis was performed using the Statistical Package for Social Sciences (SPSS). In addition, all error bars shown in the figures below represent a 95% confidence interval of the mean.

6.2 Effect of Moisture Content

Figure 7 below presents the testing results obtained from the NDG and non-nuclear devices on compacted samples prepared at varying moisture contents (i.e., 2% below OMC, at OMC, and 2% above OMC). The results in Figure 7a represent the density values obtained using the NDG for all aggregate samples. In the case of NAT-2 and RCA the density values for samples compacted at 2% below and 2% above OMC were lower than those samples compacted at OMC. This trend was expected for it follows the same trend that is observed in the laboratory conducted Proctor tests. Meaning, the density of the samples is expected to be the highest when compacted at OMC. This trend was also observed for NAT-1 and DGA samples compacted at 2% below OMC, however this trend was not observed for those samples compacted at 2%

above OMC. These density values for NAT-1 and DGA samples were slightly higher (within 2 lbs./ft³) than those samples compacted at 2% below and OMC. Although the results for NAT-1 and DGA do not follow the expected moisture-density relationship trends, it is believed that the NDG might not be sensitive enough to detect changes in the density of the samples when increasing/decreasing the moisture by only 2%. This assumption is also observed for the results obtained for NAT-1 samples compacted at OMC in that the densities measured for these samples ranged between 105 to 112 lbs./ft³, which are overlapping with the results obtained for samples compacted at 2% above OMC. A similar observation can be seen for DGA samples compacted at OMC and 2% above OMC. In addition, the Proctor moisture-density relationships for NAT-1 material, presented in Figure 7a, showed variability within 3 lbs./ft³ when the moisture content was increased/decreased by 2% from the OMC.

The modulus results obtained using the BCD on the aggregate samples are presented in Figure 7b below. As seen in this figure, the modulus values for the DGA and RCA aggregates increased when the moisture content of the samples increased. However, in the case of the NAT-1 and NAT-2 aggregates, the modulus of samples decreased when the samples moisture content increased. The results obtained for the BCD might suggest that the device is sensitive to changes in the moisture content within the samples. The observations made for all aggregates types can be attributed to the general nature of the device during testing. The conclusions made from the study conducted by Weidinger et al. [4] suggest that the placement of the BCD must be near perfect to ensure accurate results. This observation might explain the different results obtained for DGA and RCA as these aggregates contain larger aggregate particles than the natural sand materials,

therefore the placement of the device may have been skewed. In addition, Nazzal et al. [10] concluded that the BCD results might be affected when tested on very soft materials. The conclusions made from Nazzal et al. [10] might also explain why different trends were observed for the natural sand samples.

It is also worth noting that the high variability observed for all aggregates can be credited to the variability of each individual measurement collected from the BCD. To further explain, as mentioned in the previous chapters, four modulus values are measured using the BCD at one location within the sample. As can be seen in Figure 7b, the four modulus values measured varied significantly (between 5 and 35 MPa) for all aggregate samples. Therefore, the high variability observed might also be the reason why the DGA and RCA data do not show a similar trend to those seen for the NAT-1 and NAT-2 samples. In addition, the modulus values obtained for NAT-1 and NAT-2 were significantly greater (between 15 and 30 MPa) than those obtained for DGA and RCA (between 7 and 11 MPa) indicating that the BCD was able to detect the changes between aggregate types.

Figure 7c below presents the modulus values obtained using the LWD on all aggregate samples. As can be seen in this figure, the modulus values obtained for NAT-1 and RCA were similar at all moisture levels (i.e., 2% below OMC, at OMC, and 2% above OMC). The observations made for both of these aggregates suggests that the LWD was not influenced by changes in the sample moisture content when prepared at 2% below or 2% above the OMC. However, for the NAT-2 and DGA aggregates, the modulus values measured decreased as the moisture content of the samples increased. For these specific aggregate types, the LWD was able to capture the changes in modulus as

the moisture content of the samples increased. The mixed trends observed for the LWD can be attributed to several different factors such as the change in the samples moisture content as well as the different aggregate types.

Based on previous reports, the results of the LWD might have also been influenced by the size of the mold utilized for the compacted samples. In this study, samples were prepared in a mold that was 12-inches (30.5-cm) thick and 17-inches (43.2-cm) wide. Based on the study conducted by Nazzal et al. [10], the LWD was reported to have an influence depth ranging between 10.6 to 11-inches (26.9 to 27.9-cm). Although the mold utilized in this study was larger than the reported influence depth, it was not significantly larger (about 1-inch (2.5-cm) larger); therefore the LWD results might have also been influenced by the mold size. The observations made by Nazzal et al. [10] might further explain the mixed trends observed for the LWD results presented. Similar to the observations made for the BCD, Figure 7c shows that the LWD was capable of capturing the differences between the aggregate types.

The number of blows required to penetrate the 1-foot (30.5-cm) thickness of the compacted samples using the DCP are presented in Figure 7d below. As can be seen from the figure, the number of blows for NAT-2 decreased (from 4 to 2 blows) as the moisture content of the samples increased. The DCP blow count also decreased, as moisture increased, from 15 to 5 blows for DGA and from 26 to 23 blows for RCA respectively. This trend observed was expected as a result of the lubricating effect that water has on the device's performance. In other words, as the water in the samples increase, the frictional resistance of the penetrating cone decreases; therefore fewer blows are needed to penetrate the soil. In the case of NAT-1, the number of blows increased (from 5 to 6) as

the moisture in the sample increases. Although the results for NAT-1 do not follow the similar trend observed for NAT-2, DGA, and RCA it can be inferred that the DCP might not have been able to detect changes in moisture content for that particle mold sample. The overall observations made for the DCP suggests that the device is influenced by the change in the moisture content in the samples up to 2% below/above OMC.

The results presented in Figure 7d also show that the DCP values for both natural sands (NAT-1 and NAT-2) were lower than those measured for the dense graded aggregates (DGA and RCA). The measured DCP blows for both natural sands ranged between 1 and 6 blows. However, in the case of DGA and RCA, the measured DCP blows ranged from 12 to 26 blows. This observation was expected as both DGA and RCA aggregates contain larger sized particles and have a well-graded dense gradation; therefore more blows are needed to penetrate these materials. The high variability observed for DGA and RCA can be attributed to the device's performance on larger sized particles. In the study conducted by Nazzal et al. [19], it was suggested that the DCP not be tested on large particles as the device may tilt inevitably affecting the testing results. This conclusion might explain why higher variability is observed for the DGA and RCA aggregates than for both natural sand materials. Nonetheless, the results obtained for the device indicate that the DCP is capable of capturing the differences between the selected aggregates types.

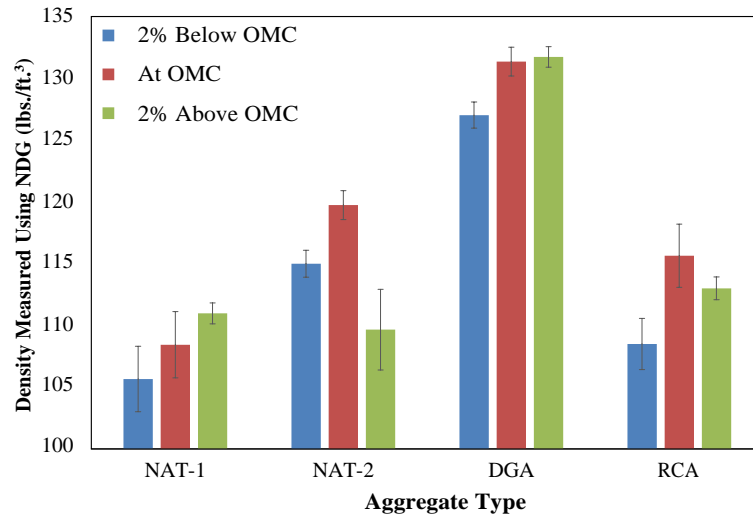

(a)

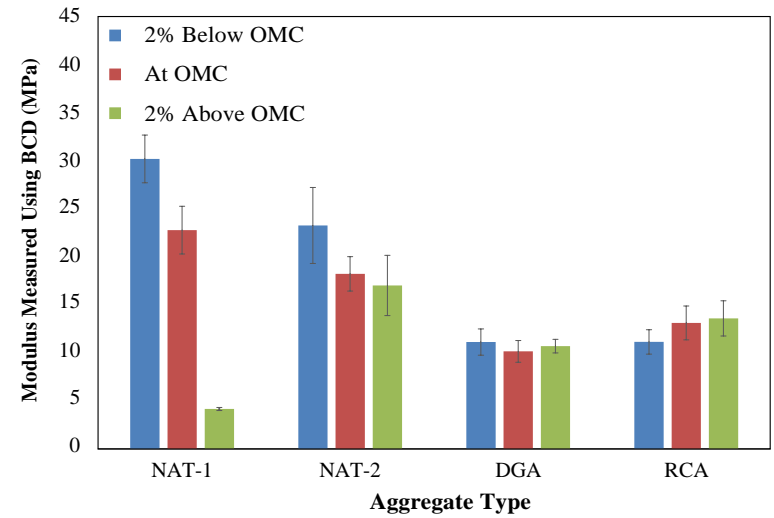

(b)

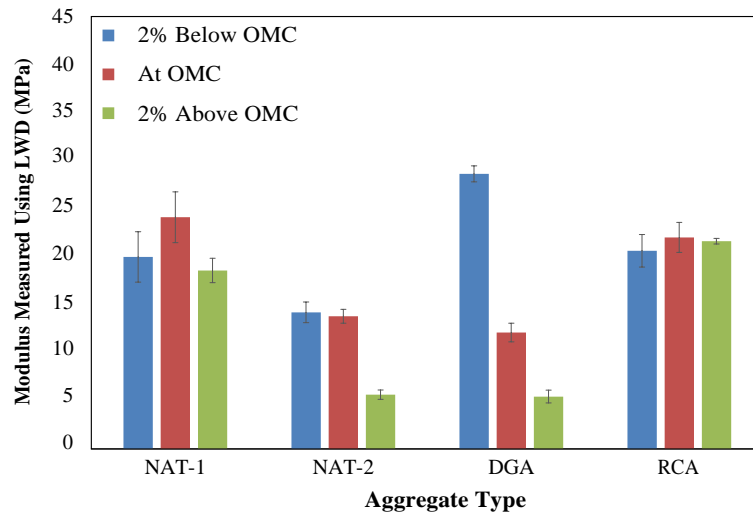

(c)

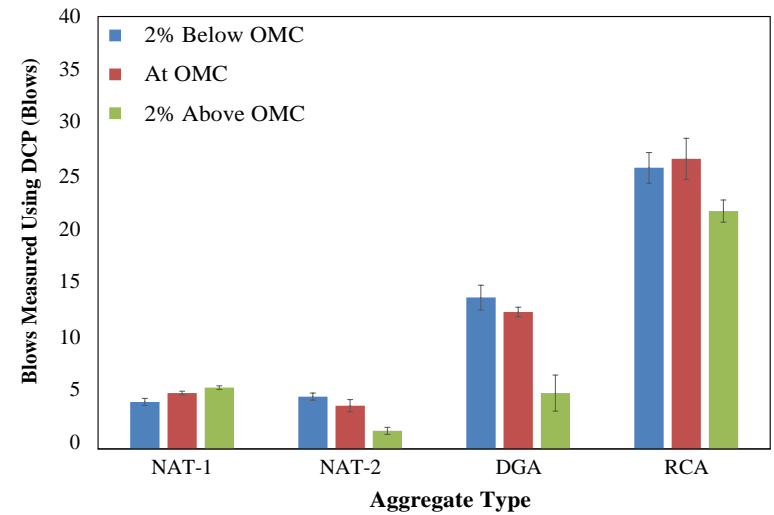

(d)

Figure 7. Effect of Moisture Content on Testing Results; (a) NDG Results, (b) BCD Results, (c) LWD Results; and (d) DCP Results

6.3 Effect of Compaction Effort

The results presented in Figure 8 below, represent the testing conducted on samples prepared at different density levels (i.e. below MDD, at MDD, and above MDD) using the NDG, BCD, LWD, and DCP. As can be seen in Figure 8a the density values measured using the NDG were the lowest for samples prepared at density levels below MDD. In addition, the densities were highest for the aggregate samples prepared at density levels above MDD. This observation was expected because as the density of the samples increase, the density as measured using the NDG should also increase. It is to be noted that these observations were made for all aggregate types.

The results presented in Figure 8a show that the differences between the NDG density values for the aggregate samples compacted at MDD and above MDD were within 3 lbs./ft³. In addition, the density values measured for the NAT-2, DGA, and RCA aggregates were significantly lower (i.e., 13 lbs./ft³) than the targeted values established in Table 17. Only in the case of NAT-1 was the measured density slightly lower (i.e., 4 lbs./ft³) than the targeted density of 120 lbs./ft³. However, to ensure that significantly higher targeted densities were obtained, a jackhammer was utilized to compact samples at density levels above MDD. Therefore, based on the observations made for the selected aggregates in conjunction with expected outcome of implementing a jackhammer for compaction, the results presented might suggest that the NDG was not capable of detecting the changes in density levels between MDD and above MDD.

Figure 8b presents the modulus values obtained using the BCD on the aggregate sample prepared at different compaction efforts. As can be seen in the figure below, the modulus values for all aggregate types were statistically similar (i.e., within 5 MPa) at all

density levels. Based on the results obtained from the BCD it can be concluded that the device was not capable of capturing the differences in the density levels selected for the compacted samples in this study. In addition, significant differences can be observed for BCD modulus values obtained for the natural sand aggregates (gap-graded) with those obtained for the DGA and RCA aggregates (dense-graded). Specifically, the BCD modulus values obtained for both NAT-1 and NAT-2 were similar in that they both measured around 20 MPa. For the case of DGA and RCA, the BCD modulus values were around 10 to 15 MPa. This observation suggests that the BCD is capable of detecting the differences in the aggregate sizes and gradations.

The high variability of the results that is observed for each aggregate type can be attributed to the general variability experienced during testing using the BCD on different soil types. Based on the previous report conducted, Nazzal et al. [19] concluded that the bending of the BCD plate on very stiff soils did not accurately measure the modulus of the samples (i.e., higher compaction). In addition, Briaud et al. [12] suggested that the BCD not be used on very soft soils (i.e., lower compaction) for the device may sink under its own weight, affecting the measured results. The high variability of the results can also be attributed to the high variability of the sample moisture content (i.e., between 1 and 4%) from the targeted moisture content that was observed for the dense graded aggregates. The observations made through both studies suggest that the BCD might be slightly influenced by different compaction efforts, however for this study, the BCD was not capable of detecting the changes in compaction efforts.

Figure 8c below presents the LWD modulus values measured for samples compacted at varying density levels. As can be seen in the figure, the modulus values for

NAT-1 and NAT-2 (gap-graded) were higher for samples compacted at MDD than those samples compacted at density levels below MDD. This observation was expected because as the compaction effort of the samples increase, the measured modulus should also increase. However, it should be noted that this trend was not observed for the DGA and RCA aggregates (dense-graded). In the case of DGA and RCA samples compacted at MDD and below MDD, the modulus values obtained using the LWD were similar (i.e., within 5 MPa). These observations made for the LWD suggests that the device might be influenced by the changes in aggregate type between samples.

As previously mentioned, the LWD modulus values measured for the NAT-2 and DGA aggregates decreased as the moisture content in the samples increased. This similar trend was observed for both materials in that as the density of the samples increased the modulus values decreased. This trend is expected because the higher density may suggest a higher degree of saturation within the sample, which would result in a lower modulus value. Based on these findings, it is concluded that the LWD is able to detect changes in the compaction effort applied to the samples. However, in the case of NAT-1 and RCA, the modulus of the samples increased as the compaction increased. Although these results do not follow the similar trends observed for NAT-2 and DGA, these results further suggest that the LWD is capable of detecting changes in density in the samples. As previously mentioned, the mixed trends obtained at samples compacted at density levels above MDD can be attributed to the effect the mold size has on the performance of the LWD.

Figure 8d below presents the DCP number of blows required to penetrate the 1-foot (30.5-cm) thick samples compacted at different density levels. As can be seen from

this figure, the number of DCP blows increased as the density level increased for all selected aggregates. The observations made for the DCP results indicate that the device was able to capture the differences between compaction efforts applied between samples. The trend observed for all aggregates types was expected in that the denser the aggregate structure is the harder it is to penetrate; therefore a higher number of blows are required for the soil.

The results presented in the Figure 8d also show that the DCP blows measured for both natural sands (NAT-1 and NAT-2) were lower than those values obtained for both dense graded aggregates (DGA and RCA). It is worth mentioning that these differences for the selected aggregates types are more substantial at higher compaction levels than lower compaction levels.

The observations made for the results of the DCP were consistent with the study by Humboldt et al. [27], in that penetration rates measuring using the DCP were higher for lightly compacted materials. Based on these findings, it can be concluded that the DCP is capable of detecting both changes in density levels as well as aggregate type between the different samples.

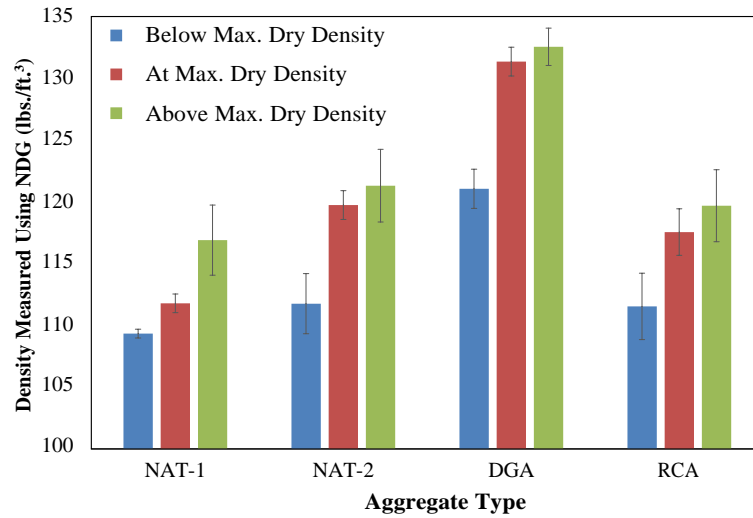

(a)

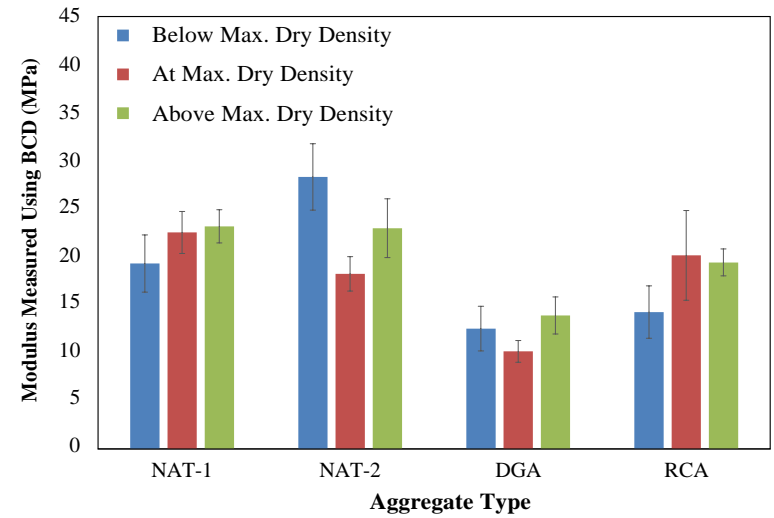

(b)

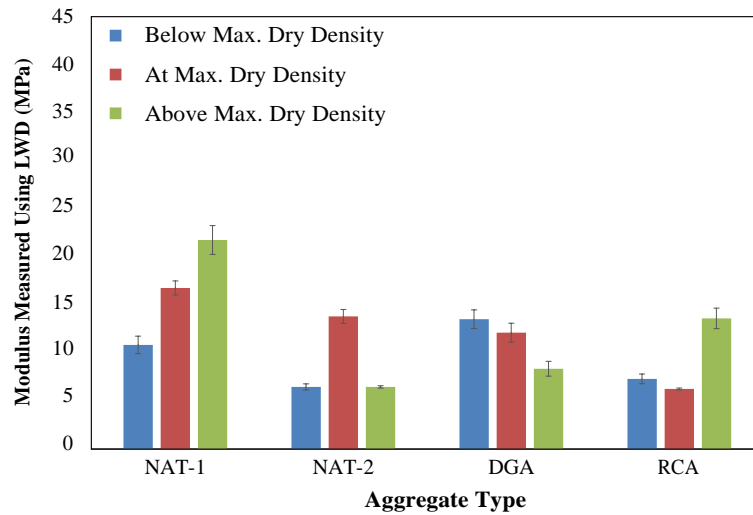

(c)

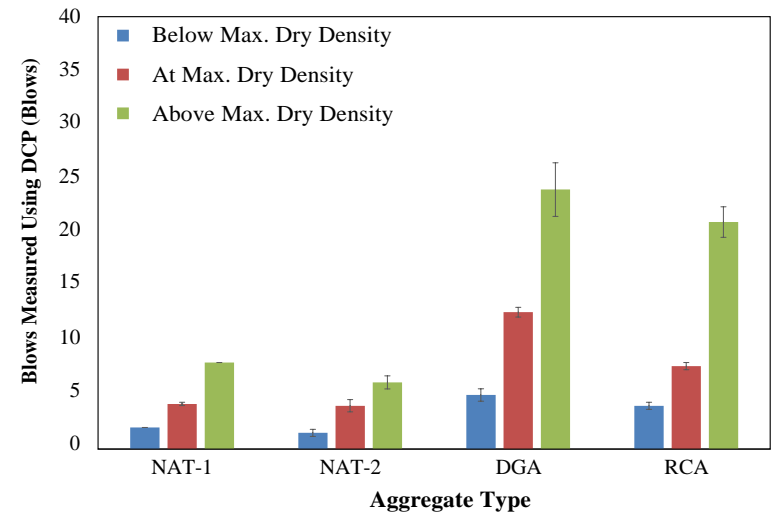

(d)

Figure 8. Effect of Compaction on Testing Results; (a) NDG Results, (b) BCD Results, (LWD) Results, and (d) DCP Results

6.4 Effect of Testing Time on Accuracy and Repeatability of Selected Devices

Figure 9 below presents the testing results obtained from the NDG, BCD, LWD, and DCP on the compacted samples prepared at OMC and MDD. The results presented were obtained immediately after the samples were compacted (i.e., 1 hour), 24 hours, and 48 hours following compaction. As can be seen in the figure, the density values measured using the NDG were relatively similar (i.e., within 5 lbs./ft³) for all testing times. However, there was a slight increase in density as testing was delayed. These observations were made for all aggregates types.

The slight increase in density can be mainly attributed to the migration of water to the bottom of the compacted sample. To further explain, prior to compaction, the aggregates are uniformly mixed with water using a concrete mixer. Once the aggregates are mixed with the appropriate amount of water, the aggregates are placed and compacted into an aluminum mold (as described in Chapter 5). After the initial day of testing the samples are covered for 24 hours and tested again using the NDG and selected devices. This process is repeated for another 24 hours following the second set of testing. During these 48 hours, the water within the samples might seep to the bottom of the mold due to gravity; explaining the slight increase in density over time. In addition, the NDG density values obtained from the samples were measured at 4-inches, 6-inches, and 8-inches throughout the mold and averaged together for one density value. Therefore, if water were to seep to the bottom of the mold the density values measured at 4-inches would be different than those values measured at 8-inches, causing an observed change in the density of the sample.

It is worth mentioning that the moisture content values, as measured using the NDG, also decreased with the delay in testing time. To further explain, as shown in Table 18 below, the NDG moisture content for NAT-1 immediately after compaction was 4.85%. After 48 hours the final measured NDG moisture content was 2.9%. Similar observations were made for the NAT-2, DGA, and RCA aggregate samples in that the NDG moisture content decreased (i.e., approximately 1.0%) with the delay in testing time. This observation might also explain the increase in the density of the sample with time. Based on the observations made for the NDG, it can be concluded that the device was capable of reproducing results between testing days. The day in which testing was conducted, did not influence the results obtained for the NDG. It is worth mentioning that for DGA aggregates, testing was only conducted immediately and 48 hours following compaction, as the device and certified technician were not available 24 hours after compaction.

The modulus results obtained for the BCD at different test days are presented in Figure 9b below. As can be seen from this figure, the modulus values obtained immediately after compaction were either higher or lower than the modulus values obtained 24 hours and 48 hours following compaction. This trend was observed for all selected aggregate types. The observations made for the BCD results can be attributed to the mixed trends previously experienced with the BCD. In addition, the high variability of the BCD (i.e., obtaining modulus values ranging from 5 to 35 MPa at the same location) might explain the mixed results presented in Figure 9b.

In the study conducted by Weidinger et al. [4], the BCD was tested on a rubber block eight different times in order to evaluate the devices repeatability. The results of

this study concluded that BCD modulus results varied within 4% of each other. In addition, the COV of the strain outputs was 0.5%. The results of this study indicated that there was high variability in the BCD results. Based on the observations made in this study as well as the conclusions made by Weidinger et al. [4], it is evident that the BCD is unable to replicate testing results over time. Therefore, it might be necessary to conduct field testing immediately after compaction in order to obtain accurate modulus results for the sample.

Figure 9c presents the LWD modulus values obtained for samples tested immediately, 24, and 48 hours after compaction. As illustrated in this figure, the modulus values obtained using the LWD were dependent on the aggregate type. The results measured for both natural sand materials (NAT-1 and NAT-2) were relatively similar between test days. However, in the case of DGA and RCA aggregates the LWD modulus values slightly increased with a delay in testing time. The slight increase in modulus values can be attributed to the migration of water to the bottom of the samples, specifically for the dense-graded aggregate (DGA and RCA), which contain larger sized particles. Meaning, water might move faster through these materials explaining the increase in modulus for these aggregates.

In general, the results presented indicate that the LWD could reproduce similar modulus results time after time, however, the device might still be influenced by the time of testing. Similar trends were observed for the modulus results obtained from the LWD in the study conducted by Alshibli et al. [3]. Based on the results of this study, it was concluded that the LWD provided unreliable modulus measurements. In addition, in the report provided by Hossain et al. [9] the LWD was also not capable of replicating

modulus results over time. Similar to the BCD, it is recommended to conduct LWD testing immediately following compaction to avoid overestimating the modulus of the sample.

The numbers of blows required to penetrate the 1-foot (30.5-cm) thick samples using the DCP over time is presented in Figure 9d below. The results presented in the figure show that the DCP values obtained for NAT-1 and NAT-2 aggregates immediately, 24 hours, and 48 hours after compaction were relatively similar (i.e., within 1 blow). The results obtained for both natural sand samples indicate that the DCP is capable of reproducing results up to 48 hours following compaction. Herath et al. [8] made similar conclusions in that the DCP was able to replicate the testing results on different soils types and locations.

However, for the case of DGA and RCA aggregates, the DCP values measured increased as the testing day increased. As previously established, these observations can be attributed to the migration of water to the bottom of the mold. In addition, the high permeability for DGA and RCA might also explain the increase in blows needed to penetrate the samples. In other words the high permeability of these aggregates might cause the water within the samples to seep faster to the bottom of the mold; further explaining the increase in DCP values measured over time. Similar difficulty was experienced when the DCP was tested on large aggregate samples in the report prepared by Nazzal et al. [19]. The observations made from this study in conjunction with the conclusions made through literature suggest conducting DCP testing immediately after compaction for high permeability aggregate and up to 48 hours after compaction for low

permeability aggregates. In order to avoid overestimating the measured values however, it is recommended to conduct DCP field testing immediately after compaction.

Table 18

Effect of Testing Time on NDG Moisture Content

Level Tested	Hour Tested	NAT-1	NAT-2	DGA	RCA
	Immediately	4.85	6.35	5.8	8.6
Opt. Moist. Cont. (%) & MDD (lbs./ft. ³)	24 Hours	3.45	6.2	N/A	8.8
	48 Hours	2.9	5.75	4.6	7.8

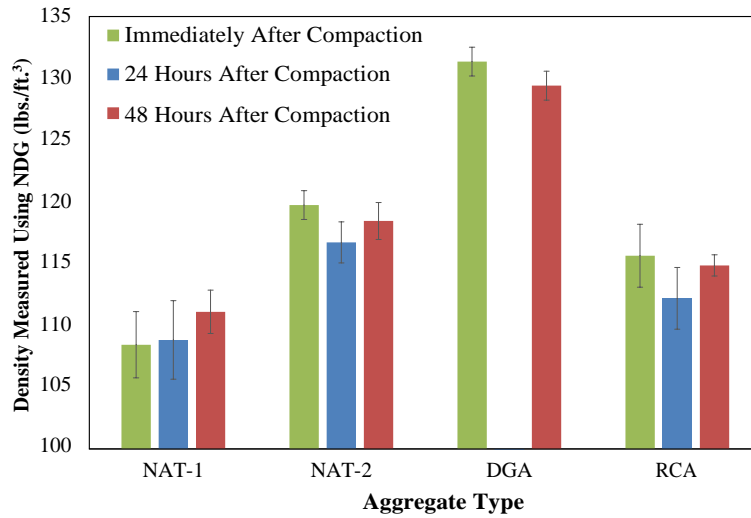

(a)

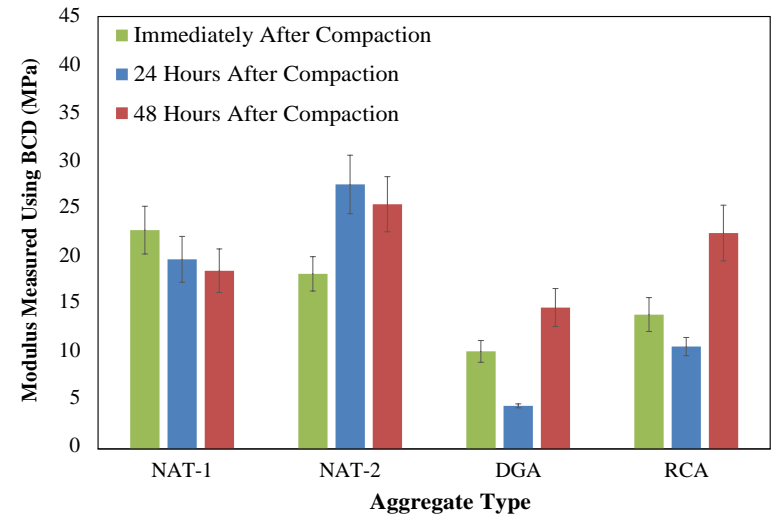

(b)

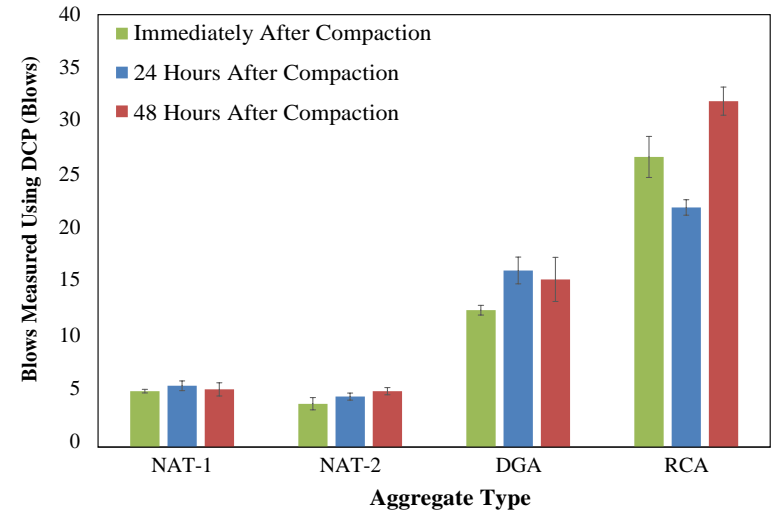
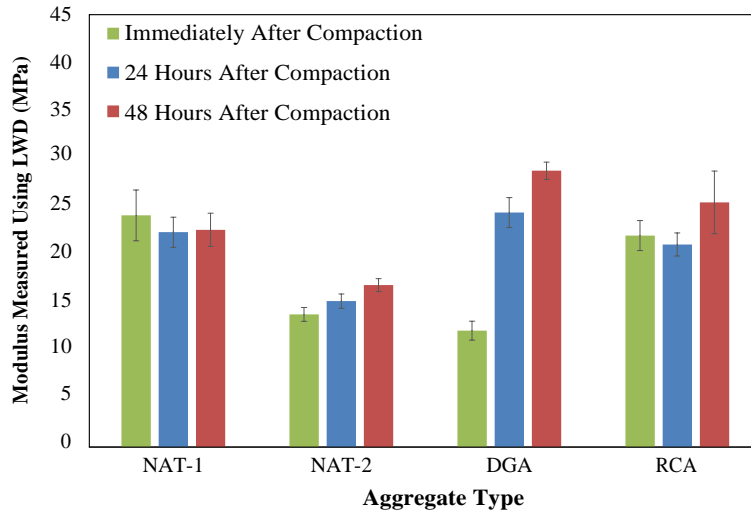

Figure 9. Effect of Delayed Testing on Testing Results; (a) NDG Results, (b) BCD Results, (c) LWD Results; and (d) DCP Results

6.5 Precision of Measurements

The standard error of the mean (SEM) was calculated for the all testing results measured immediately following compaction for NAT-1, NAT-2, DGA, and RCA respectively. These calculations were conducted in order to determine the variability of the sample mean of the results. It is to be noted that these values were expressed as a percentage of the mean value measured from the NDG and selected devices. The SEM results calculated for all laboratory testing are listed in Table 19 below.

The SEM was calculated by dividing the standard deviation (STD) of the results at 2% below, 2% above, and at OMC by the square root of the total amount of replicates measured for each device. As an example, in the case of NAT-1 the average STD calculated for the testing results at OMC was 4.481%. For this study, there were six replicates measured from each device. Therefore, the SEM was determined to be approximately 2% for NAT-1. As mentioned, this calculation was performed for all aggregate types, at all moisture levels. It is worth mentioning that a total average error of all aggregates types for each device is also presented in the table below.

As can be seen in the table, the variability of the selected devices ranged from 5-8%. Specifically, the BCD obtained a SEM of 8%, the LWD had a SEM of 5%, and a SEM of 7% was obtained for the DCP. Although the results for each device were similar, the variability of each device was greater than a SEM of 1% that was calculated for the NDG. In addition, the results show that the variability of each device at different moisture contents was similar for the NDG, BCD, and LWD. However, this was not observed for the DCP. The variability of the DCP values at 2% above OMC was slightly higher (by a difference of 6%) than at 2% below OMC and OMC. The results presented in Table 19

indicate that moisture content within 2% above or below OMC had insignificant effects on the devices measurements except in the case of the DCP. The high variability experienced with the DCP values can be attributed to the excess moisture within the samples causing the DCP blows to become more variable.

Table 19

Standard Error of the Mean of the Results Measured from all Devices (Expressed as a Percent of the Mean Value)

	Standard Error of the Mean of NDG, %			Average Error of All Materials, %
	2% Below	OMC	2% Above	
NAT-1	2%	2%	1%	1%
NAT-2	1%	1%	2%	
DGA	1%	1%	0%	
RCA	1%	2%	1%	
Average	1%	1%	1%	
Standard Error of the Mean of BCD, %				
	2% Below	OMC	2% Above	8%
NAT-1	6%	8%	3%	
NAT-2	12%	7%	13%	
DGA	9%	8%	5%	
RCA	8%	10%	10%	
Average	9%	8%	8%	
Standard Error of the Mean of LWD, %				
	2% Below	OMC	2% Above	5%
NAT-1	9%	8%	5%	
NAT-2	5%	4%	6%	
DGA	2%	6%	9%	
RCA	6%	4%	1%	
Average	6%	5%	5%	
Standard Error of the Mean of DCP, %				
	2% Below	OMC	2% Above	7%
NAT-1	5%	2%	2%	
NAT-2	5%	10%	14%	
DGA	6%	3%	23%	
RCA	4%	5%	3%	
Average	5%	5%	11%	

6.4 Summary of Findings

The results presented in this chapter illustrate the impact of moisture content, compaction effort applied, delayed testing, and aggregate type on the testing results obtained from the NDG and the selected non-nuclear devices. Based on the results of laboratory testing, it was concluded that the selected non-nuclear devices were sensitive to the changes in moisture content of the samples within 2% (above and below) the OMC. Significant effects were observed for the DCP when samples were prepared at 2% below OMC and 2% above OMC.

The results of laboratory testing indicated that the LWD and DCP were able to detect changes in compaction effort applied to the samples. However, it was concluded that the BCD was not able to capture the differences between compaction efforts. In the case of the NDG, the device was not able to capture differences between samples compacted at MDD and those compacted above MDD. In addition, the laboratory results strongly suggest that the devices were capable of replicating results up to 48 hours after compaction; however, the BCD was the only device that was unable to replicate results due to the influence of testing time.

It was also observed that all the parameters measured from the NDG and non-nuclear devices were able to differentiate between the different aggregate types. Based on the analysis conducted on the SEM results, the variability of each device at different moisture contents was similar for the NDG, BCD, and LWD. In the case of the DCP, the device showed higher variability when tested on samples prepared at moisture contents 2% above the OMC.

Overall, the analysis conducted on the laboratory testing results indicates that the DCP was the most suitable device for capturing the changes in moisture content and compaction effort applied to the prepared samples. The testing results also reveal that the DCP could reproduce results up to 48 hours after compaction. In addition, the DCP was the only device that significantly captured the differences between the compacted samples (i.e., detecting the changes in moisture within the aggregates). Ultimately, the DCP was determined to be the most promising tool that can be used to replace the NDG for determining the quality of compacted subgrade and base/subbase pavement layers.

Chapter 7

Development of DCP Multiple Linear Regression Model

7.1 Introduction

The development of a multiple linear regression model to predict field DCP blow counts is presented in this chapter. In addition, this chapter proposes a minimum DCP acceptance criteria based on the established prediction model. The prediction model developed for this study was a function of multiple factors that included: (1) material characteristics (i.e., gradation), (2) measured density, and (3) moisture content present within the sample. It was essential to determine minimum DCP blow values that would ensure satisfactory field compaction quality control during the construction of flexible pavements. A comprehensive discussion of the step-by-step process implemented to develop the prediction model is presented in the following subsections.

7.2 Separation of Collected Laboratory Data

The first step in developing the prediction model required separating the laboratory testing results collected from the NDG and selected devices. The collected data in this study consisted of 134 total points that were separated into two groups that facilitated the development and validation stage of the model. The data was separated by first randomly assigning each point with an appropriate identification number. A random table generator in Excel was then utilized to randomly select the first group of data points. The first set of data selected contained about 60% (i.e., 80 points) of the original data. This set of data served as the foundation for developing the model. The second

group of data composed of the remaining 40% (i.e., 54 points) that were used to validate the developed prediction model.

7.3 Model Formulation

The next step was to develop an initial DCP prediction model using 60% of the collected data. The initial prediction model formulated was based on several factors that included: (1) density, measured using the NDG, (2) the difference between the actual moisture content and the OMC of the sample, (3) the day of testing, (4) aggregate bulk specific gravity, and (5) aggregate gradation, represented by percent passing the No. 4 sieve and percent passing the No. 200 sieve. The difference in moisture content between the actual moisture content measured and the OMC was used to illustrate the physical behavior of the DCP in that the required number of blows increase/decrease with an increase/decrease in the aggregate moisture content.

It is noted that prior to developing the model, the DCP values were normalized by the depth of the compacted samples. This method was performed in order to account for the thickness of the sample. In addition, this procedure proved necessary when laboratory predicted DCP values were correlated to those collected through field testing in the following sections. Notice that the scale in which laboratory testing was conducted for this study was much smaller to that in which field testing was performed. Therefore, normalizing the DCP values by depth allowed both laboratory and field values to be adequately correlated to one another. Based on the factors considered, an initial DCP prediction model was established and is presented in Equation 2 below.

$$Y = AX_1 + BX_2 + CX_3 + DX_4 + EX_5 + FX_6 + G$$

Equation 2

Where:

A, B, C, D, E, F and G = Model parameters

Y = Predicted DCP blow values (blows/inch.)

X_1 = Sample density, lbs./ft.³

X_2 = Moisture content difference, %

X_3 = Testing day

X_4 = Aggregate dry bulk specific gravity

X_5 = Cumulative percent passing sieve No. 4, %

X_6 = Cumulative percent passing sieve No. 200, %

7.4 Development of Revised Model

Table 20 below presents the results of the regression analysis performed using the initial DCP prediction model established in Equation 2. The results presented in this table include the considered model parameters previously discussed and the corresponding significance value associated with each factor. As can be seen from the analysis, the moisture content difference had a significant impact on the model ($\alpha = 0.001$). In addition, the aggregate gradation, represented by percent passing No. 4 and No. 200 sieves, also had significant impacts on the developed model ($\alpha < 0.05$). However, density measured using the NDG, as well as testing day and aggregate bulk specific gravity did not have significant impacts on this model ($\alpha > 0.05$). Based on the results presented in Table 20 the insignificant factors were removed from the initial model. A regression

analysis was conducted on the revised prediction model and the results of the analysis are also presented in Table 20. As can be seen in the table, the moisture content difference and aggregate gradations remained significant on the revised model ($\alpha < 0.05$).

In order to determine if the revised model was able to capture the real physical behavior of the DCP it was necessary to study the values associated with the model parameters utilized for its development. As can be seen in the table, the moisture content difference (coefficient B) had a value of -0.107. This value suggests that as the moisture content difference increases for the sample, the required number of DCP blows will decrease. In other words, if the actual measured moisture content is higher than OMC then the number of blows required to penetrate the soil will decrease. Similarly, as the moisture content difference decreases (i.e., actual moisture content is below OMC) the number of blows needed to penetrate the sample will increase. This trend was expected as a result of the lubricating effect water has on the DCP. To further elaborate, as the water in the sample increases, the frictional resistance of the penetrating cone will decrease; therefore the number of blows needed to penetrate the soil is expected to decrease. It is worth mentioning that this trend was consistent with the observations made when the DCP was tested on laboratory samples prepared at varying moisture contents.

As can be seen in the table, the coefficient associated with percent passing sieve No. 4 (coefficient E) is -0.022. In the case of the percent passing No. 200 sieve (coefficient F), the parameter value was 0.429. These values indicate that the amount of materials passing the No. 4 sieve increases with a decrease in DCP values. Furthermore, the material passing the No. 200 sieve decreases with an increase in DCP values. These trends are expected because the materials passing the No. 4 sieve contain more fine

particles than material passing the No. 200 sieve, therefore the finer the material the lower frictional resistance applied to the penetrating cone. A lower frictional resistance will result in a lower number of blows needed to penetrate the material. These observations were also made when the laboratory testing results were compared for the well-graded aggregates (NAT-1 and NAT-2) and the dense-graded aggregate (DGA and RCA). The results of the laboratory tests showed that both natural sand materials (NAT-1 and NAT-2) required less blows than the DGA and RCA materials.

A comparison of both developed models was performed based on their COV values. As can be seen in Table 20 the initially developed model had a R-squared value of approximately 60%. The revised model, however, had a R-squared of 56%. The slight decrease in the R-squared values between the models can be attributed to the removal of the insignificant factors from the initial model. As mentioned above, the density measured using the NDG, testing day, and aggregate bulk specific gravity did not have significant impacts on the initial prediction model, therefore the slight reduction in the R-square value can be considered insignificant as well. Based on the observations made for both the initial and revised model it can be concluded that the model developed adequately captures the physical behavior of the DCP.

Table 20

Initial and Revised DCP Prediction Models

Initially Developed Model			
Model Parameters	Parameter Value	t-value	α -value
A: NDG Density	0.004	0.894	0.374
B: Moisture Content Diff.*	-0.115	-3.324	0.001
C: Testing Day	0.132	1.975	0.052
D: Agg. Specific Gravity	-2.410	-0.853	0.397
E: % Passing Sieve No. 4	-0.022	-4.350	0.000
F: % Passing Sieve No. 200	0.429	2.391	0.019
G: Constant	7.471	1.057	0.294
Model R ²	58.9%		
Revised Model			
Model Parameters	Parameter Value	t-value	α -value
B: Moisture Content Diff, %	- 0.107	-3.302	0.001
E: % Passing Sieve No. 4	- 0.025	-7.034	0.000
F: % Passing Sieve No. 200	0.264	2.630	0.010
G: Constant	2.210	8.218	0.000
Model R ²	56.0%		

The final model developed for predicting DCP blow values is as follows:

$$Y = 0.004X_1 - 0.107X_2 - 0.025X_5 + 0.264X_6 + 2.210$$

Equation 3

Where:

Y = Predicted DCP blow values (blows/inch.)

X₂ = Moisture content difference, %

X₅ = Cumulative percent passing sieve No. 4, %

X₆ = Cumulative percent passing sieve No. 200, %

7.5 Attempts to Improve Final Prediction Model

Once the final DCP prediction model was developed, attempts were made to improve the model. As mentioned in the previous sections, the prediction model required separating the collected laboratory data from the NDG and selected non-nuclear devices into two groups that aided the development and validation stage of the prediction model. The first set of data selected contained about 60% (i.e., 80 points) of the original data and the second set composed of the remaining 40% (i.e., 54 points) of the laboratory data.

The final model formulated in Equation 3 was based on several factors that included: (1) the difference between the actual moisture content and the OMC of the sample, and (2) aggregate gradation, represented by percent passing the No. 4 sieve and percent passing the No. 200 sieve. Table 20 above presents the results of the regression analysis performed on the final model. As can be seen in the table, the analysis yielded an R-squared value of 56%. It is to be noted that the COV of the moisture content of the samples utilized in this study was also calculated to determine the variability of the prepared samples. As previously mentioned (Chapter 5) moisture samples were taken between each mixing process to confirm that the targeted moisture content of the sample was reached. Table 21 below presents the measured moisture content of each sample utilized during testing. It is worth mentioning that the COV was calculated for the samples that were utilized for developing the DCP prediction model. To further explain, as mentioned in the previous sections, 60% of the collected laboratory data was utilized for developing the DCP prediction model. Therefore “N/A” in Table 21 below denotes values not utilized for developing the prediction model. Based on the actual moisture contents measured, the COV of the moisture content of the samples was 0.223. This

value was calculated by dividing the standard deviation of the samples' moisture content by the average moisture content. Based on the results of the model regression and COV analysis, attempts were made to improve the final DCP prediction model and corresponding R-squared value.

Table 21

Actual Measured Moisture Content of Prepared Samples

Experiment	Level Tested	NAT-1	NAT-2	DGA	RCA
Effect of Moisture Content (%)	2% Below OMC	8.12	7.14	6.98	8.95
	Opt. Moist. Cont.	9.58	8.99	7.82	9.9
	2% Above OMC	11.76	11.35	11.30	13.04
Effect of Compaction Effort (lbs./ft. ³)	Below MDD	9.4	10.45	7.17	15.03
	Max. Dry Density	8.98	N/A	7.68	N/A
	Above MDD	N/A	9.56	10.13	14.13

The first attempt at improving the final model involved splitting the collected laboratory data into two groups. However, rather than using 60% (i.e., 80 points) of the original data to formulate the model, 80% (i.e., 107 points) was used for its development. Once again, the model was based on: (1) the difference between the actual moisture content and the OMC of the sample, and (2) aggregate gradation, represented by percent passing the No. 4 sieve and percent passing the No. 200 sieve. A regression analysis was then performed on the model and the results are presented in Table 22 below. As can be seen in the table, all factors were significant on the model ($\alpha < 0.05$). In addition, the coefficients associated with each model parameter followed the same trend as the

previously established model (Equation 3). However, the R-squared value decreased from 56% to 47% when 80% of the original data was utilized to develop the model.

Three attempts were made to improve the final model by varying the aggregate gradation parameters. For these attempts, 80% of the original data was utilized for developing the model however, rather than using gradation parameters represented by percent passing the No. 4 and No. 200 sieve, different gradation combinations were introduced into the model. The aggregate gradation combinations included: (1) percent passing the No. 4 and No. 60 sieve, (2) percent passing the No. 60 and No. 100 sieve, and (3) percent passing the No. 60 and No. 200 sieve. The results of the regression analysis performed on these models are presented in Table 22 below. As can be seen in the table the coefficients associated with each model parameter were consistent with the final prediction model. However, the moisture content difference was not significant on any of the models ($\alpha > 0.05$). In addition, the R-squared values for these models fell below 50%.

Table 22

Prediction Model Using 80% of Data

Model Attempt 1 Using 80% Data		
Model Parameters	Parameter Value	α -value
B: Moisture Content Diff, %	-0.907	0.026
E: % Passing Sieve No. 4	-0.303	0.000
F: % Passing Sieve No. 200	2.773	0.023
G: Constant	26.994	0.000
Model R ²	47%	
Model Attempt 2 Using 80% Data		
Model Parameters	Parameter Value	α -value
B: Moisture Content Diff, %	-0.667	0.094
E: % Passing Sieve No. 4	-0.336	0.000
F: % Passing Sieve No. 60	0.62	0.192
G: Constant	28.191	0.000
Model R ²	46%	
Model Attempt 3 Using 80% Data		
Model Parameters	Parameter Value	α -value
B: Moisture Content Diff, %	-0.69	0.122
E: % Passing Sieve No. 60	-5.126	0.000
F: % Passing Sieve No. 100	9.507	0.000
G: Constant	16.315	0.000
Model R ²	35%	
Model Attempt 4 Using 80% Data		
Model Parameters	Parameter Value	α -value
B: Moisture Content Diff, %	-0.408	0.381
E: % Passing Sieve No. 60	-2.844	0.001
F: % Passing Sieve No. 200	11.192	0.000
G: Constant	15.004	0.000
Model R ²	27%	

The next attempt made to improve the final DCP prediction model involved formulating a model using 70% (i.e., 94 points) of the collected laboratory data. Once again, the initial model was based on: (1) the difference between the actual moisture content and the OMC of the sample, and (2) aggregate gradation, represented by percent passing the No. 4 and the No. 200 sieve. The results of the regression analysis performed

on the model are presented in Table 23 below. As can be seen in the table, all factors were significant on the model ($\alpha < 0.05$). However, the coefficients associated with the model parameters were not consistent with the final prediction model established in Equation 3. To further explain, the moisture content different (coefficient B) had a value of 1.483. This value indicates that as the moisture content difference increases for the sample, the number of DCP blows will increase. This trend is not expected based on the lubricating effect that water has on the DCP. If the moisture in the sample increases the frictional resistance of the penetrating cone will decrease therefore, the number of DCP blows should decrease. In addition, the R-squared value decreased from 57% to 50% when 70% of the original data was utilized for developing the model. The observations made for this model were also made when the different aggregate gradation combinations were introduced into the prediction model. Table 23 presents the regression analysis performed on the different models attempted using 70% of the collected laboratory data.

Table 23

Prediction Model Using 70% of Data

Model Attempt 1 Using 70% Data		
Model Parameters	Parameter Value	α -value
B: Moisture Content Diff, %	1.483	0.000
E: % Passing Sieve No. 4	-0.306	0.000
F: % Passing Sieve No. 200	1.965	0.000
G: Constant	27.618	0.000
Model R ²	50%	
Model Attempt 2 Using 70% Data		
Model Parameters	Parameter Value	α -value
B: Moisture Content Diff, %	1.225	0.002
E: % Passing Sieve No. 4	-0.332	0.000
F: % Passing Sieve No. 60	0.204	0.665
G: Constant	29.686	0.000
Model R ²	49%	
Model Attempt 3 Using 70% Data		
Model Parameters	Parameter Value	α -value
B: Moisture Content Diff, %	1.382	0.003
E: % Passing Sieve No. 60	-5.03	0.000
F: % Passing Sieve No. 100	9.139	0.000
G: Constant	16.27	0.000
Model R ²	36%	
Model Attempt 4 Using 70% Data		
Model Parameters	Parameter Value	α -value
B: Moisture Content Diff, %	1.159	0.017
E: % Passing Sieve No. 60	-2.78	0.001
F: % Passing Sieve No. 200	10.763	0.000
G: Constant	14.716	0.000
Model R ²	26%	

Based on the results presented in Table 22 and Table 23, efforts were then made to develop a prediction model that was aggregate specific. The first prediction model was formulated using the complete set of collected subgrade (NAT-1 & NAT-2) laboratory data (i.e., 62 points). A second model was developed using all collected base/subbase (DGA & RCA) laboratory data (i.e., 72 points). The initial models were based on: (1) the

difference between the actual moisture content and the OMC of the sample, and (2) aggregate gradation, represented by percent passing the No. 4 and the No. 200 sieve. A regression analysis was performed on the models and the results are presented in Table 24 and Table 25 below.

As can be seen in the table for the subgrade materials, the percent passing No. 200 sieve was excluded from the analysis. In addition, the percent passing No. 4 sieve was not significant on the model ($\alpha > 0.05$). It is worth mentioning that the coefficient associated with the percent passing No. 4 sieve was also not consistent with the initial prediction model (Equation 3) in that the material passing the No. 4 sieve increases as the number of DCP blows increases. As for the base/subbase model, the percent passing No. 4 sieve was excluded from the analysis however, all factors were significant on the model ($\alpha < 0.05$).

Three additional attempts were made using different aggregate gradation combinations. The different aggregate combinations once again included: (1) percent passing the No. 4 and 60 sieve, (2) percent passing the No. 60 and 100 sieve, and (3) percent passing the No. 60 and 200 sieve. The results of the regression analysis performed on these models are also presented in Table 24 and Table 25. For each model attempted, the analysis excluded one of the aggregate gradation parameters. In addition, the R-squared value for the subgrade models was 10% and the R-squared value for the base/subbase models was 20%. These observations may suggest that there is not enough data to develop a model that is aggregate specific.

Based on the results presented in this section, it was concluded that the final prediction model presented in Equation 3 most accurately predicted DCP blow counts. In addition, the model was able to capture the real physical behavior of the DCP. Therefore,

the model formulated in Equation 3 would serve as the final DCP prediction model for developing a proposed minimum DCP acceptance criteria that would ensure satisfactory field compaction quality of subgrade and base/subbase layers during pavement construction.

Table 24

Prediction Model Using NAT-1 & NAT-2 Data

Model Attempt 1 Using NAT-1 & NAT-2 Data		
Model Parameters	Parameter Value	α -value
B: Moisture Content Diff, %	-0.389	0.048
E: % Passing Sieve No. 4	0.133	0.133
F: % Passing Sieve No. 200	N/A	N/A
G: Constant	-5.875	0.398
Model R ²	10%	
Model Attempt 2 Using NAT-1 & NAT-2 Data		
Model Parameters	Parameter Value	α -value
B: Moisture Content Diff, %	-0.389	0.048
E: % Passing Sieve No. 4	N/A	N/A
F: % Passing Sieve No. 60	-0.543	0.136
G: Constant	6.881	0.000
Model R ²	10%	
Model Attempt 3 Using NAT-1 & NAT-2 Data		
Model Parameters	Parameter Value	α -value
B: Moisture Content Diff, %	-0.389	0.048
E: % Passing Sieve No. 60	N/A	N/A
F: % Passing Sieve No. 100	7.601	0.136
G: Constant	-5.715	0.404
Model R ²	10%	
Model Attempt 4 Using NAT-1 & NAT-2 Data		
Model Parameters	Parameter Value	α -value
B: Moisture Content Diff, %	-0.389	0.048
E: % Passing Sieve No. 60	N/A	N/A
F: % Passing Sieve No. 200	1.9	0.136
G: Constant	3.597	0.000
Model R ²	10%	

Table 25

Prediction Model Using DGA & RCA Data

Model Attempt 1 Using DGA & RCA Data		
Model Parameters	Parameter Value	α -value
B: Moisture Content Diff, %	-1.285	0.005
E: % Passing Sieve No. 4	N/A	N/A
F: % Passing Sieve No. 200	4.78	0.000
G: Constant	13.337	0.000
Model R ²	20%	
Model Attempt 2 Using DGA & RCA Data		
Model Parameters	Parameter Value	α -value
B: Moisture Content Diff, %	-1.285	0.005
E: % Passing Sieve No. 4	N/A	N/A
F: % Passing Sieve No. 60	2.001	0.000
G: Constant	9.491	0.000
Model R ²	20%	
Model Attempt 3 Using DGA & RCA Data		
Model Parameters	Parameter Value	α -value
B: Moisture Content Diff, %	-1.285	0.005
E: % Passing Sieve No. 60	N/A	N/A
F: % Passing Sieve No. 100	2.689	0.000
G: Constant	12.142	0.000
Model R ²	20%	
Model Attempt 4 Using DGA & RCA Data		
Model Parameters	Parameter Value	α -value
B: Moisture Content Diff, %	-1.285	0.005
E: % Passing Sieve No. 60	N/A	N/A
F: % Passing Sieve No. 200	4.78	0.000
G: Constant	13.337	0.000
Model R ²	20%	

7.6 Final Model Validation

Once the final prediction model was developed it was necessary to validate the model. As discussed in this chapter, the laboratory testing results were separated into two groups. The first set of data, consisting of 60% of the original data, facilitated the development of the model discussed above. The second group consisted of

the remaining 40% of data that were used to validate the final model. Validation of the model was completed by first predicting the field DCP values based on the considered factors. As mentioned, the considered factors included: (1) moisture difference, (2) percent passing sieve No. 4, and (3) percent passing sieve No. 200. The predicted DCP blows for each aggregate type were then plotted against the measured DCP blows in Figure 10a below. It should be noted that the equality line between the measured and predicted DCP values is also displayed in the figure.

Based on the results presented in Figure 10a it is observed that the prediction model, on average, overestimated the DCP blows up to 1.25 blows/inch. This was concluded as the majority of predicted values fell above the equality line. Since the values presented in the figure cover both natural sand materials (NAT-1 and NAT-2) it can be concluded that the developed model overestimated the DCP values for fine materials. In addition, the results presented in Figure 10a indicate that the prediction model underestimated DCP values for more coarse materials. This observation was made since the predicted values fell below the equality line for DCP values greater than 1.5 blows/inch.

In addition to the observations made, it is also worth mentioning the scattering of the plotted data around the equality line in the figure. As illustrated in Figure 10a, the scattering of the plotted data around the equality line is smaller for the fine aggregates (i.e., lower than 1.5 blows/inch.). In addition, the scattering of the plotted data is greater for the more coarse aggregates (i.e., greater than 1.5 blows/inch.). The trend was expected since that the variability of the results obtained for the coarse aggregates (i.e., DGA and RCA) was greater than those obtained for the finer aggregates (i.e., NAT-1 and

NAT-2). As illustrated in Figure 10a, the distribution of the data around the equality line is generally uniform. Based on the results presented, it is concluded that the final DCP model developed effectively predicted the measured DCP values.

To further validate the developed prediction model the absolute relative error and standard error of estimate for the data was calculated. The absolute relative error for the data was calculated as the absolute difference between the predicted DCP values and measured values. In addition, the standard error of estimate was calculated as the square root of the sum of the average error of prediction. Based on the results, the frequency distributions of the computed relative errors are presented in Figure 10b below. The results presented in the figure shows the high variability within the data. However, the high variability can be attributed to the natural non-uniformity of the different aggregate types utilized for the study. In addition, the results indicate that the majority of the predicted values (approximately 75% of the data) had an error of less than 0.5 blows/inch. Therefore, it can be further concluded that the developed DCP prediction model effectively predicted the measured DCP values.

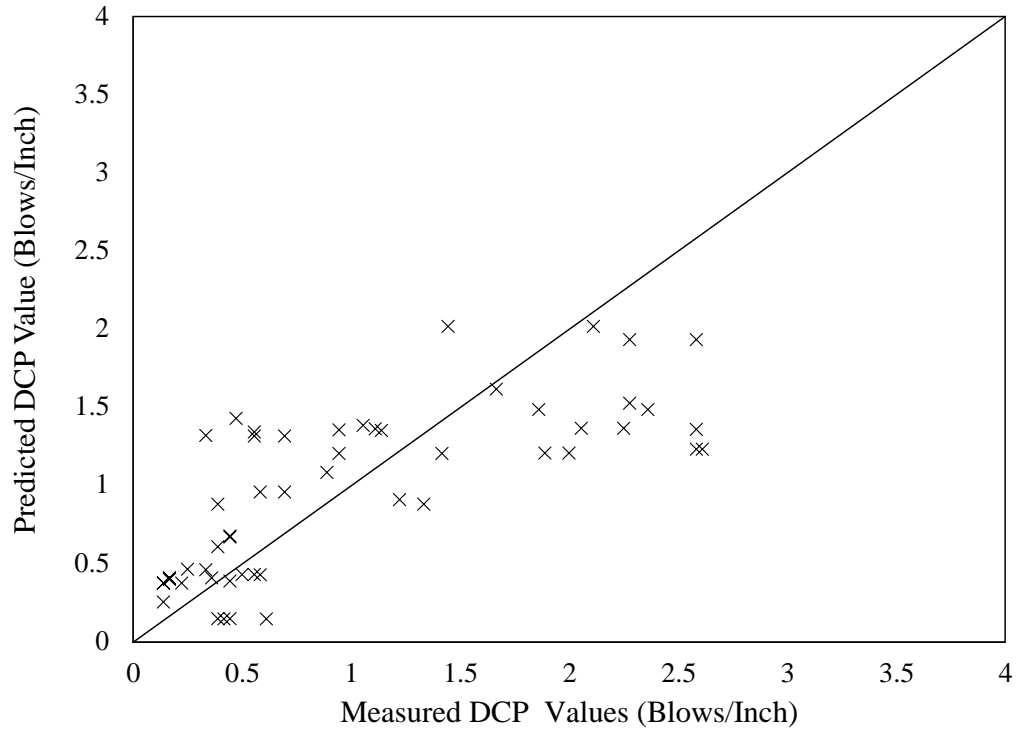

(a)

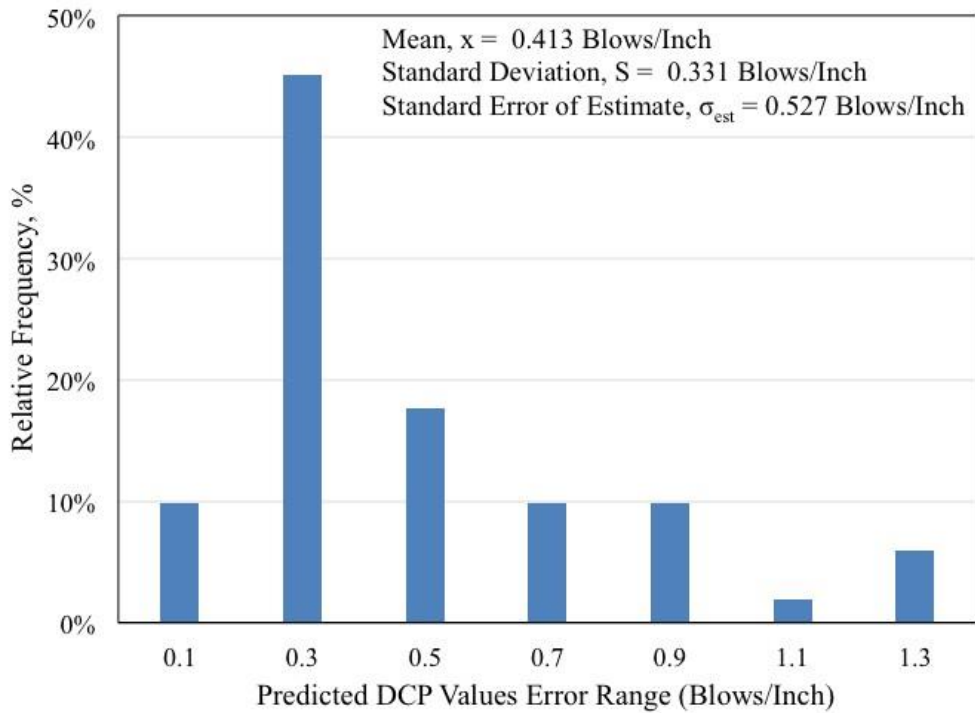

(b)

Figure 10. Verification of DCP Prediction Model; (a) Predicted vs. Measured DCP Values; and (b) Distribution of Relative Error Values

7.7 Calibration of Final Prediction Model Using Field Data

The final step for developing the DCP prediction model was to adequately calibrate the model. As mentioned previously, the compaction quality of three 100-ft (30.5-m) long field sections was measured using the NDG and non-nuclear devices. The field data collected specifically for the NDG and DCP was used to calibrate the prediction model. It was necessary to calibrate the DCP model using field measurements in order to account for the significant differences that occur between both the laboratory and field environment. As an example, when conducting testing the moisture contents measured within the field were different to those measured during laboratory testing. Therefore, it was necessary to calibrate the laboratory-based model using the data measured through field testing.

In order to calibrate the prediction model, the collected field data was categorized into four different groups according to aggregate type. The data was categorized in this fashion, as the values measured using the DCP were dependent on the selected aggregate types. To further elaborate, in the case of the natural sand materials (NAT-1 and NAT-2) the measured DCP values were higher than the values measured for both coarse aggregates (DGA and RCA). Therefore, to properly calibrate the model, a correction factor, that was aggregate specific, was utilized to correct the DCP predicted values. For each specific aggregate DCP blows were predicted based on the field moisture content, and percent passing the No. 4 and No. 200 sieves.

Due to the restrictions of field testing, it is to be noted that moisture contents were not obtained for all selected aggregates. To further explain, the limited amount of time allotted for field testing made it difficult to obtain moisture samples for the field section

containing the RCA material. In addition, prior to testing, a base layer was placed above the subgrade layers consisting of NAT-1 and NAT-2 aggregates. Therefore it was difficult to obtain moisture samples from these sections without disturbing the compacted layer. As a result of these limitations, moisture content samples were only obtained for the field sections containing the DGA aggregates. However, for the sections in which moisture samples were not collected, the moisture content was assumed to be zero or completely dry. This assumption was made, as the sections appeared completely dry during field testing. In addition the moisture contents measured for the DGA aggregates were between 1.5% and 2.0%, further confirming the assumption made.

Using the predicted and measured DCP values, a correction factor was computed for each aggregate type. The correction factor was calculated as a ratio of the average measured field DCP value to the average predicted DCP value. Figure 11 below presents an example of the calculations performed to determine the correction factor for NAT-1. As illustrated in the figure below NAT-1 had an average field DCP value of 2.512 and an average predicted value of 1.401 respectively. Therefore, the correction factor computed for NAT-1 was 1.785. Once the correction factor was computed, the value was multiplied with all the terms in the laboratory-based model. Equation 4 below presents the final DCP prediction model and the correction factors calculated for each aggregate type.

It is to be mentioned that the correction procedure selected for this study was grounded on the assumption that the field measured DCP values were uniform and did not considerably change between testing locations. As an example, in the case of the DGA field sections, the average field value ranged between 3.118 and 3.537 blows/inch. The field range was based on a 95% confidence level. The average calculated DCP was

3.327 blows/inch with a standard deviation of 1.17 blows/inch and sample size of 121 points. Similar observations were also made for the field sections containing both natural sand aggregates (NAT-1 and NAT-2) and RCA material. Therefore, based on these results, it can be inferred that the data collected through field testing was uniform and did not significantly deviate from the mean value. As a result, for each aggregate type an average value was computed using all collected field measured DCP values.

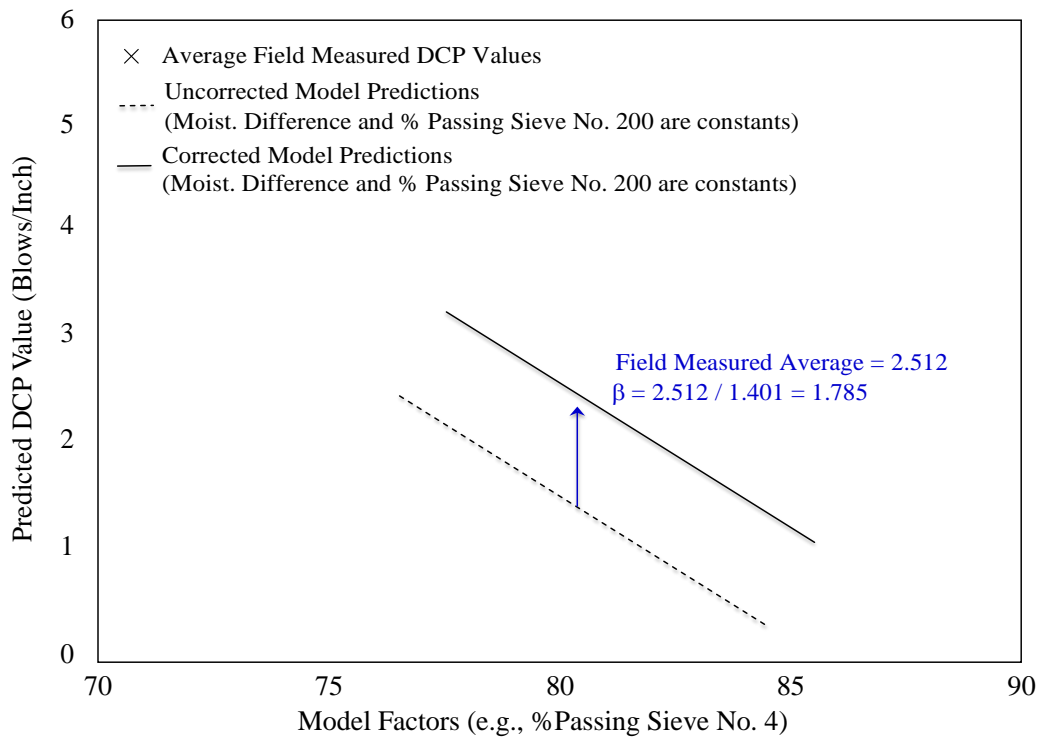

Figure 11. Computational Procedure Utilized for Computing NAT-1 Aggregates Field Correction Factor

$$Y = \beta(-0.07X_2 - 0.025X_5 + 0.24X_6 + 2.0)$$

Equation 4

Where:

Y = Predicted DCP blow values (blows/inch.)

β = Aggregate material field correction factor

(For NAT-1 use 1.785, for NAT-2 use 1.522, for DGA use 1.776 and for RCA use 2.857)

X_2 = Moisture content difference, %

X_5 = Cumulative percent passing sieve No. 4, %

X_6 = Cumulative percent passing sieve No. 200, %

7.8 Recommended Minimum DCP Acceptance Criteria

As discussed in the previous chapters, the developed DCP prediction model can be utilized for determining minimum DCP blow values that would ensure adequate field compaction quality of subgrade and base/subbase layers during the construction of pavements. Therefore, based on the DCP prediction model developed and calibrated in this study, a proposed minimum DCP acceptance criteria was established. It is to be noted that the field sections selected for testing met the NJDOT compaction quality requirements. This conclusion was made based on the data collected using the NDG that confirmed the measured density was higher than 95% of the Proctor MDD. As a result, the recommended DCP values provided in this study will qualify as the minimum DCP requirements for ensuring adequate field quality compaction.

Figure 12 below illustrates the method utilized for determining the minimum recommended DCP values. It is to be noted that the example presented in the figure

below is in reference to New Jersey soil aggregates (i.e., subgrade natural sands). The aggregates provided in this example are in accordance to the gradation designations I-1 through I-15 of the NJDOT specifications [1]. It is worth mentioning that, when determining the recommended DCP values, the variability in the moisture content, percent passing No. 4 and No. 200 sieves were taken into consideration. The variability of these factors was considered in order to recommend realistic DCP values.

As can be seen in Figure 12, the values selected for percent passing the No. 200 sieve ranged between 0 and 4%. These values were selected based on the allowable range between 0 to 8% of soil aggregates passing sieve No. 200 that is specified by the NJDOT [1]. For the purpose of this study, the allowable range for aggregates passing sieve No. 200 was utilized for NAT-1 and NAT-2 aggregates. The values selected represent the minimum (i.e., 0%) and the average of the minimum and maximum values (i.e., 0 and 8%) of the control range.

The example presented below indicates that the minimum values selected for percent passing No. 4 sieve ranged between 70 and 85%. Similar to the No. 200 sieve, these values were selected based on the control range of 40 and 100% and average of 70% for natural sands. The method for determining the input values for the percent passing No. 4 and No. 200 sieve for both natural sands was also implemented for DGA and RCA aggregates in this study.

Based on the example presented in Figure 12, for natural sands having moisture contents between 2% below OMC and OMC (i.e., 0 and -2% moisture difference) the minimum recommended DCP values were about 1.62 blows per inch of penetration. This value was computed as the overall average of all predicted DCP values instead of taking

the absolute minimum or maximum value. This method was selected in order to consider both contractor and agency risks. Using the method described above, a minimum recommended DCP value was calculated for all selected aggregates (i.e., NAT-1, NAT-2, DGA, and RCA), different moisture contents, and aggregate gradations. The results of these calculations are presented in Table 26 below. In the case of both NAT-1 and NAT-2 the recommended minimum DCP values were averaged together. Similarly an average was determined for both DGA and RCA in order to simplify the recommended specifications.

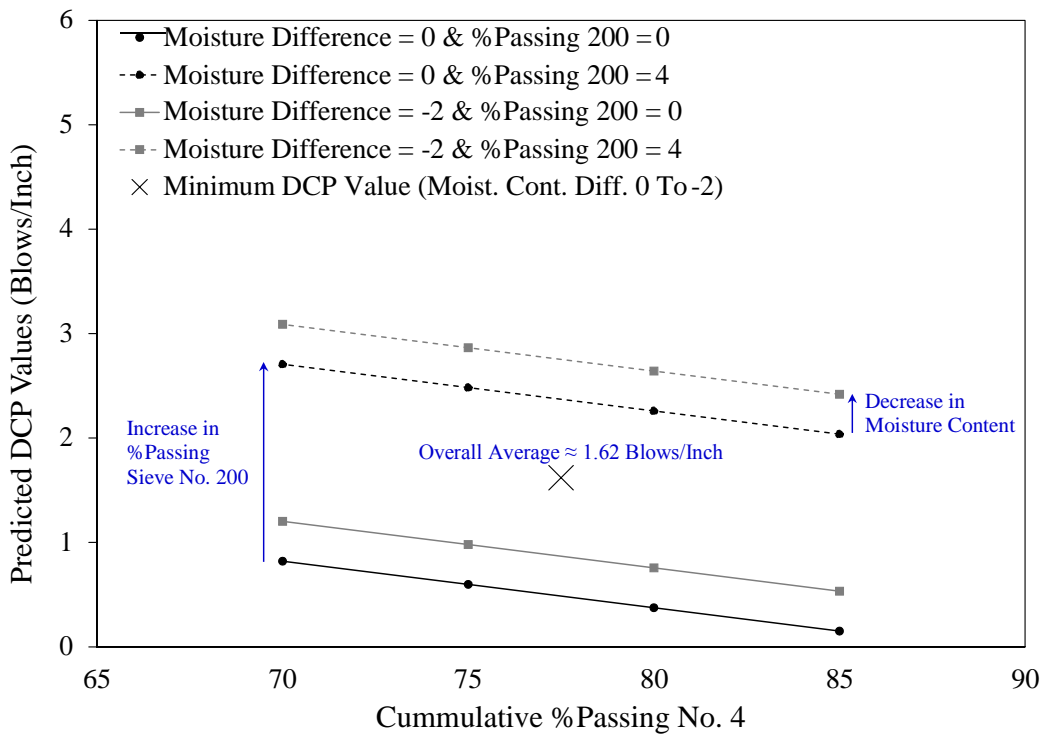

Figure 12. Example of Computed Minimum DCP Value for NJDOT NAT-1 Aggregates

Table 26

Recommended Minimum DCP Values for Ensuring Satisfactory Field Compaction

Aggregate Type	Model Input Values						Recommended Minimum DCP Value (Blows/Inch)	Recommended Minimum DCP Blows for (1-ft layer) (rounded to the nearest 5 DCP blows)
	%Passing Sieve No. 4		%Passing Sieve No. 200		Moist. Cont. Diff. (%)			
	Min	Max	Min	Max	Min	Max		
NJDOT soil aggregates (NAT-1 & NAT-2)	70	85	0	4	0	2	1.3	16 (15)
	70	85	0	4	-2	0	1.5	18 (20)
	70	85	0	4	-4	-2	1.9	23 (25)
	70	85	0	4	-6	-4	2.2	27 (25)
	70	85	0	4	-8	-6	2.6	32 (30)
	70	85	0	4	-10	-8	2.9	35 (35)
NJDOT dense graded aggregates (DGA & RCA)	30	45	0	4	0	2	3.2	39 (40)
	30	45	0	4	-2	0	3.4	41 (40)
	30	45	0	4	-4	-2	3.8	46(45)
	30	45	0	4	-6	-4	4.1	50 (50)
	30	45	0	4	-8	-6	4.5	54 (55)
	30	45	0	4	-10	-8	4.9	59 (60)

Chapter 8

Development of DCP Draft Specification

8.1 Introduction

The development of a draft specification for use of the DCP for compaction quality control of unbound subgrade and base/subbase pavement layers is discussed in this chapter. The draft specification developed for this study was based on the recommended minimum DCP values determined in Chapter 6. The minimum DCP acceptance criteria developed would ensure satisfactory field compaction during the construction of unbound flexible pavements. The following subsections discuss earlier modulus-based specifications that have been developed and the process implemented to develop the DCP draft specification presented in Appendix B.

8.2 Previously Developed DCP Specifications

As mentioned in the literature review (Chapter 2), modulus-based specifications have been developed for using the DCP during the compaction quality control stage of pavement construction. The MnDOT, Missouri Department of Transportation (MoDOT), and the Indiana Department of Transportation (InDOT) have been the leading state DOTs to develop such specifications. Nazarian et al. [16] has also developed modulus-based construction specifications for compaction of earthwork and unbound aggregates.

8.2.1 Minnesota Department of Transportation (MnDOT)

In the MnDOT specifications the DCP penetration index is used for the acceptance of three types of unbound granular materials [32]. These materials consisted

of base and edge drain trench filter aggregates, and granular subgrade materials. Based on the MnDOT specifications, testing using the DCP is to be conducted on the compacted materials and the readings for the first five drops are to be recorded. Using the first two values as seating drops, a SEAT value is computed with the following equation:

$$SEAT = \frac{D_1 + D_2}{2}$$

Equation 5

It is worth mentioning that the SEAT value is determined in order to ensure that the aggregate base layer has necessary surface strength that would support the weight of the equipment during construction. In addition, the penetration depth measured following the 5th drop is used to compute the DPI as follows:

$$DPI = \frac{D_5}{3}$$

Equation 6

In addition to testing using the DCP, the MnDOT specifications require that the gradation and in-situ moisture content be determined for the compacted material. The gradation of the material is determined by performing a sieve analysis with the 25, 19, 9.5, 4.75, 2.00-mm, 425-micrometer, and 75-micrometer sieves. Using the determined moisture content and gradation values the maximum allowable DPI can be calculated with the following equation:

$$M_{\text{max}} \left(\frac{\text{mm}}{\text{lbw}} \right) = 4GN + 18MC - 14$$

Equation 7

Where:

MC = Moisture content at the time of testing

GN = Grading number obtained using the following equation:

$$GN = \frac{25 \text{ mm} + 19 \text{ mm} + 9.5 \text{ } \mu\text{m} + 4.75 \text{ mm} + 2.00 \text{ mm} + 425 \text{ } \mu\text{m} + 75 \text{ } \mu\text{m}}{100}$$

Based on the specifications provided by the MnDOT, the compacted material is accepted if the measured SEAT and DPI values are found to be less than or equal to the calculated maximum allowable values. The maximum allowable SEAT and DPI values determined by the MnDOT are presented in Table 27 below.

Table 27

MnDOT Maximum Seat and DPI Values [32]

Grading Number	Moisture Content	Maximum Allowable SEAT (mm)	Maximum Allowable DPI	Test Layer in. (mm)
3.1 – 3.5	< 5.0	40	10	4 -6 [100 - 150]
	5.0 – 8.0	40	12	
	> 8.0	40	16	
3.6 – 4.0	< 5.0	40	10	4 -6 [100 - 150]
	5.0 – 8.0	45	15	
	> 8.0	55	19	
4.1 – 4.5	< 5.0	50	13	5 -6 [100 - 150]
	5.0 – 8.0	60	17	
	> 8.0	70	21	
4.6 – 5.0	< 5.0	65	15	6 - 12 [100 - 150]
	5.0 – 8.0	75	19	
	> 8.0	85	23	
5.1 – 5.5	< 5.0	85	17	7 - 12 [100 - 150]
	5.0 – 8.0	95	21	
	> 8.0	105	25	
5.6 – 6.0	< 5.0	100	19	8 - 12 [100 - 150]
	5.0 – 8.0	115	24	
	> 8.0	125	28	

8.2.2 Missouri Department of Transportation (MoDOT)

The DCP specification provided by the MoDOT has a similar framework to that of the MnDOT specification. The MoDOT specification however is primarily for Type 7 aggregate base materials (limestone or dolomitic, and crushed stone or sand and gravel bases) under roadways and shoulders [32]. The MoDOT specifications requires the materials be compacted to achieve an average DPI value less than or equal to 0.4-inch/blow (10-mm/blow). In addition, the measured average DPI should compare within 0.1-inch/blow (2.54-mm/blow) of the determined average DPI provided by the MoDOT.

The DPI values for these materials are calculated using Equation 6 as proposed by the MnDOT. Furthermore, under the MoDOT specifications, it is required that testing be conducted within 24 hours after compaction using a standard DCP device with a 40-lb. (18-kg) hammer.

8.2.3 Indiana Department of Transportation (INDOT)

The InDOT developed a DCP specification for the acceptance of clay, silty, or sand soils, granular soils, and chemical modified soils [33]. Granular soils used in this specification were of aggregate sizes smaller than $\frac{3}{4}$ -inch (19-mm), structural backfill size of 1-inch (25.4-mm), $\frac{1}{2}$ -inch (12.7-mm), and No. 4 and 30. The DCP acceptance criteria developed is based on the type of soil being tested, and the materials MDD and OMC values. According to the InDOT specifications the DCP is to be tested on clay soils for every 6-inches (15.2-cm) of compaction. However for silty and sandy soils, the DCP is tested for each 12-inches (30.5-cm) of compaction. In addition, for chemically modified soils the DCP is tested for every 8-inches (20.3-cm) of compacted material, and for granular materials testing is conducted for every 12-inches (30.5-cm) of compaction.

According to the InDOT specifications, a modified version of the one-point Proctor test is to be used for determining the materials MDD and OMC values. The values obtained through testing using the DCP are to be compared to the minimum required DCP values presented in Table 28 or computed using Equation 7 below. In addition, under the InDOT specifications the compacted material is to be maintained within -3% to +1% of the OMC and the moisture content is to be measured every day of

testing. Figure 13 below also illustrates the diagram used to determine the DCP acceptance criteria based on the MDD and OMC of the material.

Table 28

InDOT Minimum Required DCP Values [33]

Optimum Moisture Content (%)	(NDCP) req. 0 ~ 12 in.
10	18
11	16
12	14
13	13
14	11

$$(NDCP)_{req|0-12 in} = 5^{OMC}$$

Equation 7

Where:

OMC = Optimum moisture content

(NDCP)req|0~12 in. = Minimum required blow count for 0 to 12 in. penetration rounded to nearest integer.

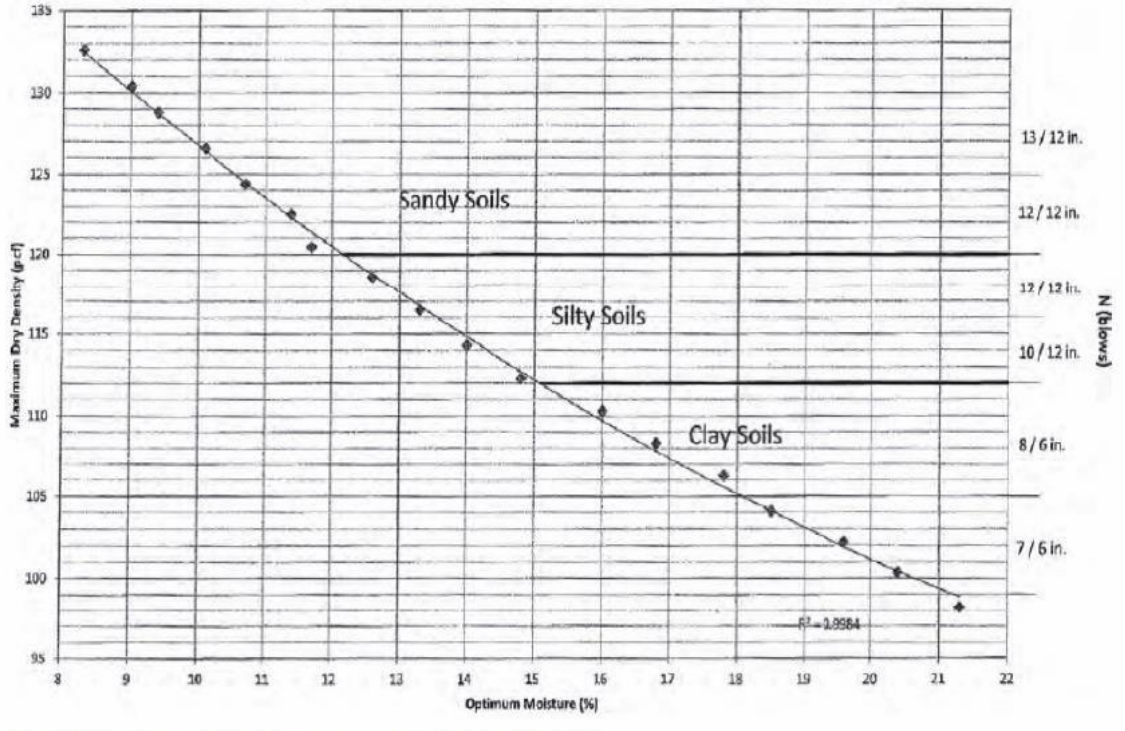

Figure 7. InDOT DCP Acceptance Criteria Based on MDD and OMC of Soil [33]

8.2.4 NCHRP Project 10-84

Nazarian et al. [16] also developed a standard specification for modulus-based quality management of earthwork and unbound aggregates. The specifications pertained to the construction of embankments and pavement layers composing of subgrade, subbase, and base materials. The DCP specifications were based on the materials gradation, moisture content, and density at compaction. According to provided specifications the acceptable materials are to meet the gradation requirements presented in Table 29. Any unacceptable material is to be corrected by the contractor. Any material that is corrected or replaced is to be sampled and tested to ensure the material passes the gradation requirements.

Table 29

NCHRP Material Gradation Requirements [16]

Material	Percent Difference from Target Gradation			
	Sieve 1-inch. (25.0 mm)	Sieve No. 4 (4.75 μm)	Sieve No. 40 (425 μm)	Sieve No. 200 (75 μm)
Embankment (if applicable)	10%	10%	10%	10%
Subgrade	10%	10%	10%	10%
Subbase	5%	8%	5%	3%
Base	5%	8%	5%	3%

In addition to the gradation requirements for the material, the NCHRP specifications calls for a specific range of moisture content in which the material can fall within during the compaction process. The moisture content specifications are presented in Table 30 below. In addition, moisture content samples are to be taken at random prior to compaction. If the materials do not meet the requirements the materials are to be corrected until the appropriate moisture content is reached.

Table 30

NCHRP Moisture Content Requirements [16]

Optimum Moisture Content (OMC)	Moisture Content	
	Min.	Max.
<10%	OMC - 2%	OMC + 2%
≥10%	0.8 OMC	1.2 OMC

The final requirements, as determined by the NCHRP specifications, are that each lift is to be compacted to no less than the percent of maximum dry density presented in Table 31. According to the specifications, samples for density testing will be taken at

random prior to compaction. Once again, if the material does not meet the set requirements it is to be corrected accordingly. Testing using the DCP should be conducted in a timely manner prior to the moisture content of the layer falling below 1% of the moisture content measured during the time of compaction. For materials with an OMC greater than 10%, the moisture content is not to fall below 2% of the moisture content.

Table 31

NCHRP Relative Density Requirements for Compaction [16]

Material	Min. Required Relative Density
Embankment	85% of Maximum Dry Density
Subgrade	90% of Maximum Dry Density
Subbase	95% of Maximum Dry Density
Base	95% of Maximum Dry Density

8.3 Development of DCP Draft Specification

The existing draft specifications provided through literature concentrated on developing construction specifications using values predicted from modulus-based devices. However, a majority of these studies were limited to certain subgrade aggregates and did not extensively cover materials that are generally used for pavement construction. In addition, the draft specifications presented contain required moisture content specifications. As a result, a draft specification for use of the DCP for compaction quality control based primarily on material characteristics (i.e., gradation) for subgrade and base\subbase materials was developed. It was necessary to develop such specification in

order to shift from density-based acceptance that encompasses moisture content within its specifications to modulus-based acceptance of materials.

Appendix B presents the proposed DCP draft specification titled “Compaction Quality Control of Unbound Subgrade and Base/Subbase Layers Through Use of the Dynamic Cone Penetrometer.” The proposed specification includes a set of guidelines for implementing the DCP as an acceptance tool for the compaction quality control stage of pavement construction. Specifically within the specification are two recommended procedures for conducting the DCP test. In addition, a set of material gradation and moisture content acceptance criteria are proposed. The following subsections discuss the components that make up the developed DCP specification and the justification behind each proposal.

8.3.1 Device and Materials

The first two components of the draft specification comprise of the device description and general material use requirements. The DCP test is to be conducted in accordance to ASTM D6951 or ASTM D7380 standards [34]. Within the specifications it is recommended that the contractor use aggregate materials that conform to the NJDOT 901.11 requirements of the Standard Specifications for Road and Bridge Construction [1]. This step is necessary to ensure that material is suitable for the intended use during construction. In addition, it is worth noting that adequate compaction of a material will not necessarily guarantee the success and long-term endurance of the material. Therefore, it is important that the materials used for the development of the subgrade or base/subbase layers met the specifications as provided by the NJDOT.

8.3.2 DCP Test Procedure

Once the accepted material is placed and compacted into the respective layer it was necessary to establish a method for conducting the DCP test. The proposed specification provides two procedures for conducting the test which include: (1) a control strip, and (2) random selection of test points. The two test procedures were provided to allow different test method options for various types of construction sites.

The first proposed test method requires constructing a 400-square yard (334.5-square meter) or greater control strip at the designated site. Once the control strip is developed the DCP test can be conducted at 10 randomly selected locations within the area. A minimum of 10 locations is preferred in order to ensure a certain level of confidence in the measured values.

The second test method provided in the specification is a random selection of test points. Based on this procedure, it is recommended to conduct the DCP test at 10 randomly selected locations within the site at a minimum of 3-feet (0.9-m) increments of each other. This test method was provided for when a control strip was not necessary for the designated site. However, since a definite testing boundary is not specified a minimum of 3-feet (0.9-m) increments between DCP tests is recommended.

It is also worth mentioning that the methods described above were similar to the procedure proposed in 203.03.02B of the NJDOT specifications for determining the compaction requirements based on density acceptance [1]. For the purpose of this study, it was appropriate to follow a similar protocol for the DCP test, as it may ultimately replace the density-based method for compaction quality control. Using either test

methods provided, an average DCP value can be calculated from the measured values.

The proposed specification also recommends that the DCP test be conducted until a depth of 15-inches (38.1-cm) of the compacted layer is reached. For areas in which the depth of the layer is less than 15-inches (38.1-cm) the test should be conducted for the entire thickness of the layer. It is to be noted that during laboratory testing with the DCP, mold samples were prepared at a depth of 12-inches (30.5-cm), therefore a value of 15-inches (38.1-cm) was deemed appropriate for the purpose of developing the DCP test procedure requirements. In addition, it is recommended that the test be performed within 24 hours of the placement and compaction of the aggregate layer. This requirement was preferred based on the results of laboratory testing that showed higher variability for the DCP when tested on compacted samples prepared 48 hours after compaction. In order to avoid overestimating DCP measurements, it is preferred that testing be conducted no later than 24 hours after compaction.

8.3.3 Acceptance Criteria

The final component of the developed DCP specification was the minimum acceptance criteria for the compacted material layer. The acceptance criteria utilized for developing the proposed specification (Table 26) was based on the material characteristics that included: (1) gradation, and (2) moisture content within the material.

According to the specification, the materials used for constructing subgrade and base/subbase layer should be in accordance to the gradation designations I-1 through I-15 of the NJDOT specifications [1]. It is recommended that these specifications apply to the material throughout the entire placement and compaction process of the layer. Acceptable

gradation specifications can be maintained through implementing one of the random sampling procedures specified in AASHTO T 2 [35]. As mentioned in Section 8.3.1, it is important to use material that met the requirements provided by the NJDOT specifications to ensure satisfactory material performance. The proposed material specifications are presented in Table 32 below.

Table 32

NJDOT Materials Specification

Material	Specification
NJDOT Subgrade	NJDOT 901.11
NJDOT Base/Subbase	NJDOT 901.11

The second set of requirements proposed in the draft specification incorporated a moisture content control option. Initially a specification that was based solely on material gradation was established. The minimum acceptable DCP values (rounded to the nearest 5 blows) determined are presented in Table 33 below. According to the proposed specification, acceptable NJDOT subgrade materials require 1.5 blows/inch and approximately 20 blows for 1-foot (30.5-cm) of compacted material. In addition, acceptable NJDOT base/subbase materials require 3.4 blows/inch and approximately 40 blows for 1-foot (30.5-cm) of compacted material. The minimum acceptable values presented in the table below were selected in order to account for any additional moisture in the compacted layer that was within $\pm 2\%$ of the OMC. Meaning, if the compacted layer was believed to contain additional moisture then the material would still meet the proposed specification as long as it fell within the range determined in the table.

Table 33

Minimum Acceptable DCP Values Based on Gradation

Material	Percent Passing (%)				Minimum DCP Value (blows/inch.)	Minimum DCP Blows for (1-ft layer) (rounded to the nearest 5 DCP blows)
	Sieve No. 4 (4.75 mm)		Sieve No. 200 (75 µm)			
	Min.	Max.	Min.	Max.		
NJDOT Subgrade	40	100	0	8	1.5	18 (20)
NJDOT Base/Subbase	25	50	3	10	3.4	41 (40)

A second specification that included moisture content was developed for when the moisture within the compacted material deviated significantly from the OMC. The gradation and moisture content requirements and the corresponding minimum DCP blow values are presented in Table 34. It is to be noted that four minimum acceptable DCP blows were determined for each material type to cover moisture content up to $\pm 6\%$ of the OMC. In order to measure the moisture within the material the specification recommends collecting moisture content samples at random prior to compaction that is in accordance to a random sampling procedure provided in ASHTO T 2 [35].

Table 34

Minimum Acceptable DCP Values Based on Gradation & Moisture Content

Material	Percent Passing (%)				Moist. Cont. Diff. (%)		Minimum DCP Value (blows/inch.)	Minimum DCP Blows for (1-ft layer) (rounded to the nearest 5 DCP)
	Sieve No. 4 (4.75 mm)		Sieve No. 200 (75 µm)		Min.	Max.		
	Min.	Max.	Min.	Max.			Min.	Max.
NJDOT Subgrade	40	100	0	8	0	2	1.3	16 (15)
	40	100	0	8	-2	0	1.5	18 (20)
	40	100	0	8	-4	-2	1.9	23 (25)
	40	100	0	8	-6	-4	2.2	27 (25)
NJDOT Base/Subbase	25	50	3	10	0	2	3.2	39 (40)
	25	50	3	10	-2	0	3.4	41 (40)
	25	50	3	10	-4	-2	3.8	46 (45)
	25	50	3	10	-6	-4	4.1	50 (50)

8.3.4 Document Results

The final component of the developed draft specification requires documenting the results from the DCP test conducted. The following information is to be recorded and submitted to the RE:

1. The number of blows required to penetrate the layer between test readings;
2. Cumulative depth of penetration after each set of hammer blows;
3. Difference in cumulative penetration between each reading;
4. The penetration depth per blow;
5. The rate of penetration between each test reading; and
6. Assessment on acceptable/unacceptable compacted material.

Chapter 9

Conclusions and Recommendations

9.1 Conclusions

The determination of a non-nuclear alternative method(s) to the NDG through laboratory and field testing was presented in this thesis. The proposed objective was based on the existing concerns and safety risks associated with using the NDG as an acceptance tool during the compaction of unbound base/subbase layers. Laboratory testing to evaluate the effect of aggregate type, moisture content, compaction effort, and delayed testing on the measured parameters of the NDG, BCD, LWD, and DCP was conducted to determine the most suitable non-nuclear alternative for replacing the NDG. In addition, the results of the laboratory tests conducted in this study were utilized for the development of a multiple linear regression model for predicting field measured DCP values. The developed prediction model was then validated by plotting the predicted field DCP values against the measured DCP values. To further validate the prediction model, the absolute relative error and standard error of estimate for the data was calculated and analyzed. The developed model was also calibrated using measured DCP field values from three 100-ft (30.5-m) long field sections. Ultimately, a set of guidelines for implementing the DCP and draft specifications for using the device as a quality acceptance tool in the compaction quality control stage of pavement construction was developed.

Based on the results of the analyses conducted, the following conclusions were made:

- 1) Based on the moisture content and density values measured before and after the compaction process, the developed procedure for preparing and compacting large aggregate samples for validating non-nuclear alternative devices appears to be practical for laboratory testing.
- 2) The actual moisture content samples obtained from each lift during the implemented procedure were within $\pm 0.5\%$ of the targeted moisture content. In addition, the density values measured using the NDG following compaction of the samples were within ± 5 lbs./ft.³ of the targeted density value for all aggregate types. The analysis conducted on both moisture content and density confirms the quality of the compaction procedure.
- 3) Three devices were selected for further investigation as a non-nuclear alternative to the NDG for evaluating unbound subgrade and base/subbase pavement layers. The devices selected for additional laboratory and field assessment were the BCD, LWD, and DCP. The device selection was based on the literature review conducted on the different alternative devices as well as the survey sent to state DOT materials engineers, device manufacturers, and contractors.
- 4) Analysis of the NDG results indicates that the device is not sensitive enough to detect changes in density of the samples when increasing/decreasing the moisture content by $\pm 2\%$ of the OMC. The density values for samples compacted at 2% below and 2% above OMC were lower than those compacted at OMC for both the NAT-2 and RCA materials. However, this trend was not observed for the NAT-1 and DGA samples

- compacted at 2% above OMC. In addition, the Proctor moisture-density relationships for the NAT-1 material show variability within 3 lbs./ft³ when increasing/decreasing the moisture content by 2%.
- 5) The NDG testing results also show that the density values measured were lowest at density levels below MDD and highest at levels above MDD. This is expected as the density in the samples increase the density measured by the NDG should increase as well. However, the density values for samples at MDD and above MDD were within 3 lbs./ft³ suggesting that device is not capable of detecting changes between MDD and above MDD.
 - 6) The BCD testing results suggest that the BCD is sensitive to changes in the moisture content. The modulus values for the DGA and RCA aggregates increased when the moisture content of the samples increased. However, in the case of the natural sand materials (NAT-1 and NAT-2) the modulus of the samples decreased as the moisture increased. The trends observed can be attributed to the high variability of the BCD and general nature of the device during testing.
 - 7) Analysis of the BCD results indicates that the BCD was not capable of capturing the differences in compaction efforts. The modulus values as measured using the BCD were statistically similar (i.e., within 5 MPa) at all density levels. In addition, significant differences were observed for the natural sand materials and dense-graded materials indicating that the BCD is sensitive to aggregate type.
 - 8) Analysis of the LWD testing results shows that the modulus values for NAT-1 and RCA were similar at all moisture levels. This observation suggests the LWD is not influenced by changes in the moisture content of the sample.

- 9) The LWD testing results show that LWD is influenced by the change in compaction effort. For the NAT-2 and DGA samples the modulus of the samples decreased as the density of the samples increased. In the case of NAT-1 and RCA the modulus of the samples increased as the compaction increased. The mixed trends observed can be attributed to the effect of mold size on the performance of the LWD.
- 10) The DCP testing results suggest that the DCP is influenced by the change in moisture content within the samples. The DCP blow count decreased as moisture increased for the NAT-2, DGA, and RCA materials. This is due to the lubricating effect that water has on the DCP performance.
- 11) Analysis of the DCP testing results show that the number of DCP blow increased as the density level increased for all aggregate types, indicating that the DCP is sensitive to differences in compaction effort applied between the samples. In addition, the DCP values for both natural sand materials (NAT-1 and NAT-2) were lower than those measured for the dense graded aggregates (DGA and RCA) indicating that the DCP is also sensitive to aggregate type.
- 12) The variability, as determined through comparison of the SEM results, was similar for the NDG, BCD, and DCP. The DCP however, shows an increase in variability when the aggregate samples were prepared at moisture contents 2% above the OMC.
- 13) Based on the analysis conducted the DCP was selected as the most applicable tool for replacing the NDG in determining the quality of compacted unbound pavement layers.
- 14) A DCP model to predict laboratory and field DCP measured values was developed. The model was based on multiple factors that included: (1) material characteristics

- (i.e., gradation) represented by cumulative percent passing sieve the No. 4 and No. 200 sieve, and (2) moisture content present within the sample. The model development composed of formulating an initial prediction model. The model was then revised and attempts were made to improve the final model. Upon completion of the final model it was then validating and calibrating using field measured DCP values.
- 15) The DCP prediction model was utilized for determining a proposed minimum DCP blow value that would ensure satisfactory field compaction quality control during pavement construction.
 - 16) Using the proposed minimum DCP acceptance criteria, a draft specification for using the DCP for compaction quality control of unbound subgrade and base/subbase pavement layers was developed.

9.2 Recommendations

Based on the analysis and the conclusions presented above, the following recommendations are suggested for future work on this study:

- 1) A jackhammer was utilized for compacting laboratory prepared samples at higher targeted density levels. However, laboratory results show that the measured density values for samples compacted above MDD were lower (i.e., 13 lbs./ft³) than their targeted values. Therefore it is recommended implementing an alternative method for compacting samples to significantly higher density levels.
- 2) Out of the three 100-ft long field sections that were analyzed, moisture content samples were only collected for two field sections. Due to the time restriction during

field testing, samples were only collected on the sections containing the DGA material. Therefore, for further analysis, moisture samples should be collected at all additional tested field sections.

- 3) The field testing conducted was limited due to the lack of available sections. It is recommended to analyze additional field sections to improve the developed DCP prediction model.
- 4) The proposed DCP prediction model is based on a linear relationship between the different measured parameters (i.e., moisture content and aggregate gradation). However, some studies have developed prediction models using a non-linear relationship. Therefore it is recommended to look into non-linear relationships for developing the proposed DCP prediction model.

References

- [1] New Jersey Department of Transportation. *Standard Specifications for Road and Bridge Construction*. New Jersey. 2007.
www.state.nj.us/transportation/eng/specs/2007/Division.shtml. Accessed May 1, 2015.
- [2] Lenke, L., McKeen, R., & Grush, M. Laboratory Evaluation of GeoGauge for Compaction Control. In *Transportation Research Record: Journal of Transportation Research Board*, No. 1849, Transportation Research Board of the National Academies, Washington, D.C., 2003, pp. 20-30.
- [3] Alshibli, K., Abu-Farsakh, M., & Seyman, E. Laboratory Evaluation of the GeoGauge and Light Falling Weight Deflectometer as a Construction Control Tool. *ASCE Journal of Materials in Civil Engineering*, Vol. 17, No. 5, 2005, pp. 560-569.
- [4] Weidinger, D., Laboratory Evaluation of the Briaud Compaction Device. *Journal of Geotechnical and Geoenvironmental Engineering*, Vol. 135, No. 10, 2009, pp. 1543-1546.
- [5] Chen, D.H., Wang, J.N., & Bilyeu, J. Application of Dynamic Cone Penetrometer in Evaluation of Base and Subgrade Layers. In *Transportation Research Record: Journal of Transportation Research Board*, No. 1764, Transportation Research Board of the National Academies, Washington, D.C., 2001.
- [6] Abu-Farsakh, M., Nazzal, M., Alshibli, K., & Seyman, E. Application of Dynamic Cone Penetrometer in Pavement Construction Control. In *Transportation Research Record: Journal of the Transportation Research Board*, No. 2016, Transportation Research Board of the National Academies, Washington D.C., 2007, pp. 51-61.
- [7] Murad, Y., Abu-Farsakh, M. Assessment of In-Situ Test Technology For Construction Control of Base Courses and Embankments, Report No. FHWA/LA.04/385, Louisiana Transportation Research Center, Baton Rouge, LA, 2004.
- [8] Herath, A., Mohammad, L., Gaspard, K., Gudishala, R., & Abu-Farsakh, M. *The Use of Dynamic Cone Penetrometer to Predict Resilient Modulus of Subgrade Soils*. Report No. FHWA-LAW-417, FHWA, Washington, DC, 2007.

- [9] Hossain, M.S., & Apeageyi, A.K. Evaluation of the Light Weight Deflectometer for In Situ Determination of Pavement Layer Moduli, Report No. FHWA/VTRC-10-R6, Virginia Transportation Research Council, Richmond, 2010.
- [10] Nazzal, M., Abu-Farsakh, M., Alshibli, K., & Mohammad, N. Evaluation the LFW Device for in Situ Measurement of Elastic Modulus of Pavement Layers. In *Transportation Research Record: Journal of the Transportation Research Board*, No. 2016, Transportation Research Board of the National Academies, Washing D.C., 2007, pp. 13-22.
- [11] Peterson, J. S., Romanoschi, S. A., & Hossain, M., *Development of Stiffness-Based Specifications for In-Situ Embankment Compaction Quality Control*. Report No. K-TRAN: KSU-04-6, Kansas Department of Transportation, Manhattan, 2007.
- [12] Briaud, J.-L., Rhee, K., & Saez, D. The BCD: A New Instrument for Compaction Control. In *Transportation Research Record: Journal of the Transportation Research Board*, Transportation Research Board of the National Academies, Washington D.C., 2009.
- [13] Mohammad, L., Gaspard, K., Herath, A., & Nazzal, M., *Comparative Evaluation of Subgrade Resilient Modulus from Non-Destructive, In-Situ and Laboratory Methods*. Report No. FHWA/LA.06/417, Louisiana Transportation Research Center, Baton Rouge, 2007.
- [14] Salgado, R., & Yoon, S. *Dynamic Cone Penetration Test (DCPT) for Subgrade Assessment*, Joint Transportation Research Project No. C-36-45S, Purdue University, West Lafayette, Ind., 2003.
- [15] Davich, P., Camargo, F., Larsen, B., Roberson, R., & Siekmeier, J. *Validation of DCP and LWD Moisture Specifications for Granular Materials*. Report No. MN/RC-2006-20, Minnesota Department of Transportation, St. Paul, 2006.
- [16] Nazarian, S., Mazari, M., Abdallah, I., Puppala, A.J., Mohammad, L. N., Abu-Farsakh, M.Y. Modulus-Based Construction Specification for Compaction of Earthwork and Unbound Aggregates. NCHRP Report 10-84. In *Transportation Research Record: Journal of the Transportation Research Board*, No. 10-84, Transportation Research Board of the National Academies, Washington, D.C., 2014.

- [17] Wu, S., Sargand. *Use of Dynamic Cone Penetrometer in Subgrade and Base Acceptance*. Report No. FHWA/ODOT-2007-01, FHWA, Washington, DC, 2007.
- [18] White, D.J. Earthwork Performance Specification Integrating Proof Mapping and Alternative In-Situ Testing. SHRP2 Report R07. In *Transportation Research Record: Journal of the Transportation Research Board*, No. R07, Transportation Research Board of the National Academies, Washington, D.C., 2014.
- [19] Nazzal, M. Non-Nuclear Methods for Compaction Control of Unbound Materials. NCHRP Report 456. In *Transportation Research Record: Journal of the Transportation Research Board*, No. 456, Transportation Research Board of the National Academies, Washington, D.C., 2014.
- [20] Von Quintus, H. L, Minchin, R. E., Nazarian, S., Maser, K. R., & Prowell, B. NDT Technology for Quality Assurance of HMA Pavement Construction. NCHRP Report 626. In *Transportation Research Record: Journal of the Transportation Research Board*, No. 626, Transportation Research Board of the National Academies, Washington, D.C., 2009.
- [21] Simmons, C., *Letter of Finding: Memorandum to the Missouri Department of Transportation Research, Development and Technology Division*. 2000.
- [22] Bloomquist, D., Ellis, R. D., & Birgisson, B. *Development of Compaction Quality Control Guidelines That Account for Variability in Pavement Embankments in Florida*. Report No. BC-287, University of Florida Department of Civil and Coastal Engineering, Gainesville, 2003.
- [23] Miller, H., & Mallick, R. *Field Evaluation of a New Compaction Monitoring Device*. New England Transportation Consortium, 2003.
- [24] Romero, P. Evaluation of Non-Nuclear Gauges to Measure Density of Hot-Mix Asphalt Pavements. SHRP2 Report 1813. In *Transportation Research Record: Journal of the Transportation Research Board*, No. 1813, Transportation Research Board of the National Academies, Washington, D.C., 2002, pp. 47-54.
- [25] Maher, A., Bennert, T., & Gucunski, N. *Evaluation of the Humboldt Stiffness Gauge*. Report No. FHWA-NJ-2002_0002, Rutgers the State University of New Jersey, Piscataway, 2002.

- [26] Mooney, M. A., Nocks, C. S., Selden, K. L., Bee, G. T., & Senseney, C. T. *Improving Quality Assurance of MSE Wall and Bridge Approach Earthwork Compaction*. Report No. CDOT-2008-11, Colorado Department of Transportation, Denver, 2008.
- [27] Humboldt Mfg. Co. GeoGauge User Guide. Version 4.1, Elgin, IL. 2007. http://www.humboldtscientific.com/download/pdf/H-4140_MAN_0712.pdf. Accessed May 15, 2015.
- [28] Manjunath, K. C., & Amarnath, M. S., Structural Evaluation of Low Volume Road Pavements Using Pavement Dynamic Cone Penetrometer. *International Journal of Research in Engineering and Technology*, No. 1, 2013.
- [29] Roctest Telemac Smartec. Instruction Manual: Soil Modulus Device for Bearing Capacity and Compaction Control. No. E10304-110510. 2011. http://www.roctest.com/content/download/1284/12285/file/e10304-110510_bcd.pdf. Accessed May 15, 2015.
- [30] American Society for Testing and Material (ASTM). *Standard Test Method for Laboratory Compaction Characteristics of Soil Using Modified Effort*. Publication number D1557-07, ASTM, Washington, DC, 2007.
- [31] Roctest Telemac Smartec. Instruction Manual: Soil Modulus Device for Bearing Capacity and Compaction Control. No. E10304-110510. 2011. http://www.roctest.com/content/download/1284/12285/file/e10304-110510_bcd.pdf. Accessed May 15, 2015.
- [32] Minnesota Department of Transportation: Grading & Base Quality Control/Quality Assurance (QC/QA): Pilot Specification. 2005-06. <http://www.dot.state.mn.us/materials/gbmodpi.html>. Accessed September 1, 2015.
- [33] Indiana Department of Transportation of Transportation Office of Materials Management: Field Determination of Strength Using Dynamic Cone Penetrometer. No. 509-15P. 2015. http://www.in.gov/indot/div/mt/itm/pubs/509_testing.pdf. Accessed September 1, 2015.

- [34] American Society for Testing and Material (ASTM). *Use of the Dynamic Cone Penetrometer in Shallow Pavement Applications*. Publication number D6951M - 09, ASTM, Washington, DC, 2009.
- [35] American Association of State Highway and Transportation Officials (AASHTO). *Standard Method of Test for Sampling of Aggregates*. Publication number T 2, AASHTO, Washington, DC, 2006.

Appendix A

Survey of Alternative Devices

A.1 Survey Questions

1. Which of the following best describes your profession?
 - a. Manufacturer of the nuclear density gauge
 - b. Manufacturer of alternative device (specify)
 - c. Contractor
 - d. DOT personnel/engineer
 - e. Other:

2. Are you familiar with the nuclear density gauge? With (1) being no knowledge whatsoever, and (5) being used/researched on a regular basis.
 - a. Not at all (1)
 - b. Slightly (2)
 - c. Moderately (3)
 - d. Substantially (4)
 - e. Expert (5)

3. What are the major advantages of using the nuclear density gauge?
 - a. Repeatability and accuracy (1) (2) (3) (4) (5)
 - b. Quick/Timely device measurement output (1) (2) (3) (4) (5)
 - c. Ease of data processing and interpretation (1) (2) (3) (4) (5)

4. What are the major disadvantages of using the nuclear density gauge?
 - a. Expensive and timely training and certification (1) (2) (3) (4) (5)
 - b. Specialized and isolated storage (1) (2) (3) (4) (5)
 - c. Expensive cost and operation cost (1) (2) (3) (4) (5)
 - d. Potential safety hazards (1) (2) (3) (4) (5)
 - e. Density measured rather than a design property (1) (2) (3) (4) (5)

5. Select all of the following devices you have previously used:
 - a. GeoGauge
 - b. Dynamic cone penetrometer
 - c. Light weight falling deflectometer
 - d. Briaud compaction device
 - e. PaveTracker
 - f. Other:

g. None

6. For alternative devices to the nuclear density gauge, please rank the importance of the following criteria, 1 being not important 5 being extremely important:

- | | | | | | | |
|----|--|-----|-----|-----|-----|-----|
| a. | Repeatability of field measurements | (1) | (2) | (3) | (4) | (5) |
| b. | Time needed for field measurements | (1) | (2) | (3) | (4) | (5) |
| c. | Ease of data processing and int. | (1) | (2) | (3) | (4) | (5) |
| d. | Sensitivity to enviro. factors (moisture) | (1) | (2) | (3) | (4) | (5) |
| e. | Ease of use and accuracy | (1) | (2) | (3) | (4) | (5) |
| f. | Cost | (1) | (2) | (3) | (4) | (5) |
| g. | Additional comments about the factors listed as well as other factors/parameters not listed: | | | | | |

7. The GeoGauge: (*Where 1 is Strongly Disagree, 5 is Strongly Agree*)

- | | | | | | | |
|----|---|-----|-----|-----|-----|-----|
| a. | Has high repeatability and accuracy | (1) | (2) | (3) | (4) | (5) |
| b. | Provides easy data processing | (1) | (2) | (3) | (4) | (5) |
| c. | Has optimal operation and testing time | (1) | (2) | (3) | (4) | (5) |
| d. | Contains high ease of use | (1) | (2) | (3) | (4) | (5) |
| e. | Is not affected by enviro. factors (moisture) | (1) | (2) | (3) | (4) | (5) |
| f. | Not negatively affected by lower layer properties | (1) | (2) | (3) | (4) | (5) |
| g. | Has reasonable cost | (1) | (2) | (3) | (4) | (5) |
| h. | Readings properly represent field conditions (various levels of compaction/density) | | | | | |

8. Based on your experience with the GeoGauge, state the negative and positive experiences unique to this device:

9. The dynamic cone penetrometer: (*Where 1 is Strongly Disagree, 5 is Strongly Agree*)

- | | | | | | | |
|----|---|-----|-----|-----|-----|-----|
| a. | Has high repeatability and accuracy | (1) | (2) | (3) | (4) | (5) |
| b. | Provides easy data processing | (1) | (2) | (3) | (4) | (5) |
| c. | Has optimal operation and testing time | (1) | (2) | (3) | (4) | (5) |
| d. | Contains high ease of use | (1) | (2) | (3) | (4) | (5) |
| e. | Is not affected by enviro. factors (moisture) | (1) | (2) | (3) | (4) | (5) |
| f. | Not negatively affected by lower layer properties | (1) | (2) | (3) | (4) | (5) |
| g. | Has reasonable cost | (1) | (2) | (3) | (4) | (5) |
| h. | Readings properly represent field conditions (various levels of compaction/density) | | | | | |

10. Based on your experience with the dynamic cone penetrometer, state the negative and positive experiences unique to this device.

11. The light weight falling deflectometer:

- a. Has high repeatability and accuracy (1) (2) (3) (4) (5)
- b. Provides easy data processing (1) (2) (3) (4) (5)
- c. Has optimal operation and testing time (1) (2) (3) (4) (5)
- d. Contains high ease of use (1) (2) (3) (4) (5)
- e. Is not affected by enviro. factors (moisture) (1) (2) (3) (4) (5)
- f. Not negatively affected by lower layer properties (1) (2) (3) (4) (5)
- g. Has reasonable cost (1) (2) (3) (4) (5)
- h. Readings properly represent field conditions (various levels of compaction/density)

12. Based on your experience with the light weight falling deflectometer, state the negative and positive experiences unique to this device.

13. The Briaud compaction device:

- a. Has high repeatability and accuracy (1) (2) (3) (4) (5)
- b. Provides easy data processing (1) (2) (3) (4) (5)
- c. Has optimal operation and testing time (1) (2) (3) (4) (5)
- d. Contains high ease of use (1) (2) (3) (4) (5)
- e. Is not affected by enviro. factors (moisture) (1) (2) (3) (4) (5)
- f. Not negatively affected by lower layer properties (1) (2) (3) (4) (5)
- g. Has reasonable cost (1) (2) (3) (4) (5)
- h. Readings properly represent field conditions (various levels of compaction/density)

14. Based on your experience with the Briaud, state the negative and positive experiences unique to this device.

15. The PaveTracker:

- a. Has high repeatability and accuracy (1) (2) (3) (4) (5)
- b. Provides easy data processing (1) (2) (3) (4) (5)
- c. Has optimal operation and testing time (1) (2) (3) (4) (5)
- d. Contains high ease of use (1) (2) (3) (4) (5)
- e. Is not affected by enviro. factors (moisture) (1) (2) (3) (4) (5)
- f. Not negatively affected by lower layer properties (1) (2) (3) (4) (5)
- g. Has reasonable cost (1) (2) (3) (4) (5)
- h. Readings properly represent field conditions (various levels of compaction/density)

16. Based on your experience with the PaveTracker, state the negative and positive experiences unique to this device.

17. Overall, rank the suitability of the following devices in the replacement of the nuclear density gauge from 1-5 with 1 being a very poor alternative and 5 being an excellent alternative.

- | | | | | | | | |
|----|------------------------------------|-----|-----|-----|-----|-----|------|
| a. | GeoGauge | (1) | (2) | (3) | (4) | (5) | (NA) |
| b. | Dynamic cone penetrometer | (1) | (2) | (3) | (4) | (5) | (NA) |
| c. | Light weight falling deflectometer | (1) | (2) | (3) | (4) | (5) | (NA) |
| d. | Briaud compaction device | (1) | (2) | (3) | (4) | (5) | (NA) |
| e. | PaveTracker | (1) | (2) | (3) | (4) | (5) | (NA) |

18. Based on your knowledge of the following alternative devices to the nuclear density gauge, if you had to theoretically select one of the devices for implementation, which device would you use?

- GeoGauge
- Dynamic cone penetrometer
- Light weight falling deflectometer
- Briaud compaction device
- PaveTracker
- Other:
- I still prefer nuclear density gauge

19. Please explain your rationale to the previous question.

20. Specify your agency's level of interest in stiffness/strength based devices for compaction control of unbound materials:

- Not interested
- Slightly interested
- Moderately interested
- Substantially interested
- Extremely interested

21. Specify your agency's level of interest in implementing stiffness/strength based devices for compaction control of unbound materials:

- Not interested in implementing it
- Interested, but have not implemented it
- Interested and will implement it
- Interested and have already implemented it
- Other:

22. Ultimately, do you feel a transition to an alternative device is possible?

- a. Yes
- b. No
- c. I don't know

23. Which factors/obstacles do you feel will be most challenging in the widespread implementation of a new device with (1) being not challenging and (5) being extremely challenging?

- | | | | | | |
|---|-----|-----|-----|-----|-----|
| a. Need for new equipment | (1) | (2) | (3) | (4) | (5) |
| b. Lack of funds | (1) | (2) | (3) | (4) | (5) |
| c. Lack of trained personnel | (1) | (2) | (3) | (4) | (5) |
| d. Familiarity of contractors with such devices | (1) | (2) | (3) | (4) | (5) |

24. Additional comments regarding factors that you feel will affect the widespread implementation of a new device, alternative devices, nuclear density gauge, or other aspects not covered in this survey:

A.2 Survey Results

#1 	<p>INCOMPLETE</p> <p>Collector: Web Link (Web Link) Started: Tuesday, April 22, 2014 10:48:38 AM Last Modified: Thursday, April 24, 2014 6:16:45 AM Time Spent: Over a day IP Address: 150.250.143.69</p>
--	--

PAGE 2: Introductory Questions

Q1: Which of the following best describes your profession?	Contractor
Q2: Please specify the level of knowledge/experience you have with the nuclear density gauge and its pavement engineering applications:	Moderately knowledgeable
Q3: Please rank the following statements regarding the use of the nuclear density gauge as compaction quality control method for unbound material. (1: not important and 4: the main reason it is used)	
The nuclear density gauge provides the user with accurate and repeatable readings	1
The nuclear density gauge provides the user with outputs in a quick timely manner	2
The data collected from the nuclear density gauge is easily analyzed and interpreted	3
The data collected from the nuclear density gauge is not influenced by the presence of moisture	4
Q4: Please rank the following statements regarding the nuclear density gauge. (1: not a problem and 5: detrimental to normal operation)	
The nuclear density gauge requires timely training/certification	1
The nuclear density gauge requires specialized and isolated storage	3
The nuclear density gauge is expensive to purchase and operate	4
The nuclear density gauge is potentially hazardous	5
The nuclear density gauge only measures density as opposed to strength/stiffness	2

Q5: If an alternative method/device, other than nuclear density gauge, is used as an unbound material compaction quality control method/device, please rank the importance of the following criteria used in selecting this method/device. (1: not important at all and 6: extremely important)

Repeatability of field measurements	1
Time Needed for field measurements	2
Ease of data processing	4
Sensitivity to environmental factors	3
Ease of use and accuracy	5
Cost	6

Q6: Please provide any additional comments, if you have any, about the factors considered in the previous question as well as other factors that might not have been considered:

Respondent skipped this question

PAGE 3: Alternatives Devices (Geogauge)

Q7: Have you previously used or researched on the Geogauge device?

Yes, I have used/researched on the Geogauge

PAGE 4: Geogauge

Q8: Based on your experiences using/researching on the Geogauge, please specify your level of agreement with the following statements:

The Geogauge provides the user with accurate and repeatable readings	Disagree
The data collected from the Geogauge is easily analyzed and interpreted	Neutral
The Geogauge provides the user with outputs in a quick timely manner	Neutral
The Geogauge is portable and easy to use	Strongly Disagree
The Geogauge is not affected by site's environmental conditions (e.g. moisture content)	Disagree
The Geogauge is negatively affected by properties of lower layers	Disagree
The Geogauge has reasonable cost	Disagree
The Geogauge provides the user with readings representative of field conditions	Disagree

Q9: Based on your experience, state the negative and positive experiences unique to this device:

Respondent skipped this question

PAGE 5: Alternatives Devices (Dynamic Cone Penetrometer)

Q10: Have you previously used or researched on the Dynamic Cone Penetrometer device?

No, I have not used/researched on the Dynamic Cone Penetrometer

PAGE 6: Dynamic Cone Penetrometer

Q11: Based on your experiences using/researching on the Dynamic Cone Penetrometer (DCP), please specify your level of agreement with the following statements

Respondent skipped this question

Q12: Based on your experience, state the negative and positive experiences unique to this device:

Respondent skipped this question

PAGE 7: Alternatives Devices (Light Falling Weight Deflectometer)

Q13: Have you previously used or researched on the Light Falling Weight Deflectometer device?

No, I have not used/researched on the Light Falling Weight Deflectometer

PAGE 8: Light Falling Weight Deflectometer

Q14: Based on your experiences using/researching on the Light Falling Weight Deflectometer (LFW), please specify your level of agreement with the following statements

Respondent skipped this question

Q15: Based on your experience, state the negative and positive experiences unique to this device:

Respondent skipped this question

PAGE 9: Alternatives Devices (Briaud Compaction Device)

Q16: Have you previously used or researched on the Briaud Compaction Device?

No, I have not used/researched on the Briaud Compaction Device

PAGE 10: Briaud Compaction Device

Q17: Based on your experiences using/researching on the Briaud Compaction Device (BCD), please specify your level of agreement with the following statements

Respondent skipped this question

Q18: Based on your experience, state the negative and positive experiences unique to this device:

Respondent skipped this question

PAGE 11: Alternatives Devices (PaveTracker)

Q19: Have you previously used or researched on the PaveTracker?	No, I have not used/researched on the PaveTracker
---	---

PAGE 12: PaveTracker

Q20: Based on your experiences using/researching on the PaveTracker, please specify your level of agreement with the following statements	<i>Respondent skipped this question</i>
Q21: Based on your experience, state the negative and positive experiences unique to this device:	<i>Respondent skipped this question</i>

PAGE 13: Conclusion Questions

Q22: Overall, rank the following devices/methods from "5" being a very poor alternative to the nuclear density gauge to "1" being an excellent alternative to the nuclear density gauge. Please pick N/A if you haven't had any prior experience with a particular device.	<i>Respondent skipped this question</i>
Q23: Specify your agency's/company's level of interest in stiffness/strength based devices for compaction of unbound materials	<i>Respondent skipped this question</i>
Q24: Specify your agency's level of interest in implementing stiffness/strength based devices for compaction control of unbound materials.	<i>Respondent skipped this question</i>
Q25: Ultimately, do you feel a transition to an alternative device is possible?	<i>Respondent skipped this question</i>
Q26: Based on your experience, please rank the following factors/obstacles that you feel might hinder or negatively influence the widespread implementation of a new device/method as an alternative to the nuclear density gauge. (1: no to very low influence and 4: significantly high influence)	<i>Respondent skipped this question</i>
Q27: Based on your experience, please fill in the following box with any additional comment about other factors/obstacles that you believe might hinder or negatively influence the implementation of a new device/method for use as an alternative to the nuclear density gauge:	<i>Respondent skipped this question</i>

#2

**COMPLETE**

Collector: Web Link (Web Link)

Started: Thursday, April 24, 2014 10:23:54 AM

Last Modified: Thursday, April 24, 2014 10:29:25 AM

Time Spent: 00:05:31

IP Address: 150.250.176.236

PAGE 2: Introductory Questions

Q1: Which of the following best describes your profession?	DOT Personnel/Engineer
Q2: Please specify the level of knowledge/experience you have with the nuclear density gauge and its pavement engineering applications:	Highly knowledgeable
Q3: Please rank the following statements regarding the use of the nuclear density gauge as compaction quality control method for unbound material. (1: not important and 4: the main reason it is used)	
The nuclear density gauge provides the user with accurate and repeatable readings	4
The nuclear density gauge provides the user with outputs in a quick timely manner	3
The data collected from the nuclear density gauge is easily analyzed and interpreted	2
The data collected from the nuclear density gauge is not influenced by the presence of moisture	1
Q4: Please rank the following statements regarding the nuclear density gauge. (1: not a problem and 5: detrimental to normal operation)	
The nuclear density gauge requires timely training/certification	4
The nuclear density gauge requires specialized and isolated storage	3
The nuclear density gauge is expensive to purchase and operate	2
The nuclear density gauge is potentially hazardous	1
The nuclear density gauge only measures density as opposed to strength/stiffness	5

Q5: If an alternative method/device, other than nuclear density gauge, is used as an unbound material compaction quality control method/device, please rank the importance of the following criteria used in selecting this method/device. (1: not important at all and 6: extremely important)

Repeatability of field measurements	1
Time Needed for field measurements	3
Ease of data processing	2
Sensitivity to environmental factors	4
Ease of use and accuracy	5
Cost	6

Q6: Please provide any additional comments, if you have any, about the factors considered in the previous question as well as other factors that might not have been considered:

Respondent skipped this question

PAGE 3: Alternatives Devices (Geogauge)

Q7: Have you previously used or researched on the Geogauge device?

Yes, I have used/researched on the Geogauge

PAGE 4: Geogauge

Q8: Based on your experiences using/researching on the Geogauge, please specify your level of agreement with the following statements:

The Geogauge provides the user with accurate and repeatable readings	Strongly Agree
The data collected from the Geogauge is easily analyzed and interpreted	Agree
The Geogauge provides the user with outputs in a quick timely manner	Neutral
The Geogauge is portable and easy to use	Neutral
The Geogauge is not affected by site's environmental conditions (e.g. moisture content)	Disagree
The Geogauge is negatively affected by properties of lower layers	Neutral
The Geogauge has reasonable cost	Neutral
The Geogauge provides the user with readings representative of field conditions	Neutral

Q9: Based on your experience, state the negative and positive experiences unique to this device:

Respondent skipped this question

PAGE 5: Alternatives Devices (Dynamic Cone Penetrometer)

Q10: Have you previously used or researched on the Dynamic Cone Penetrometer device?

No, I have not used/researched on the Dynamic Cone Penetrometer

PAGE 6: Dynamic Cone Penetrometer

Q11: Based on your experiences using/researching on the Dynamic Cone Penetrometer (DCP), please specify your level of agreement with the following statements

Respondent skipped this question

Q12: Based on your experience, state the negative and positive experiences unique to this device:

Respondent skipped this question

PAGE 7: Alternatives Devices (Light Falling Weight Deflectometer)

Q13: Have you previously used or researched on the Light Falling Weight Deflectometer device?

Yes, I have used/researched on the Light Falling Weight Deflectometer

PAGE 8: Light Falling Weight Deflectometer

Q14: Based on your experiences using/researching on the Light Falling Weight Deflectometer (LFWD), please specify your level of agreement with the following statements

The LFWD provides the user with accurate and repeatable readings

Strongly Disagree

The data collected from the LFWD is easily analyzed and interpreted

Neutral

The LFWD is not affected by site's environmental conditions (e.g. moisture content)

Agree

The LFWD is negatively affected by properties of lower layers

Neutral

The LFWD has reasonable cost

Agree

The LFWD provides the user with readings representative of field conditions

Disagree

Q15: Based on your experience, state the negative and positive experiences unique to this device:

Respondent skipped this question

PAGE 9: Alternatives Devices (Briaud Compaction Device)

Q16: Have you previously used or researched on the Briaud Compaction Device? *Respondent skipped this question*

PAGE 10: Briaud Compaction Device

Q17: Based on your experiences using/researching on the Briaud Compaction Device (BCD), please specify your level of agreement with the following statements *Respondent skipped this question*

Q18: Based on your experience, state the negative and positive experiences unique to this device: *Respondent skipped this question*

PAGE 11: Alternatives Devices (PaveTracker)

Q19: Have you previously used or researched on the PaveTracker? *Respondent skipped this question*

PAGE 12: PaveTracker

Q20: Based on your experiences using/researching on the PaveTracker, please specify your level of agreement with the following statements *Respondent skipped this question*

Q21: Based on your experience, state the negative and positive experiences unique to this device: *Respondent skipped this question*

PAGE 13: Conclusion Questions

Q22: Overall, rank the following devices/methods from "5" being a very poor alternative to the nuclear density gauge to "1" being an excellent alternative to the nuclear density gauge. Please pick N/A if you haven't had any prior experience with a particular device.

Geogauge	1
Dynamic Cone Penetrometer	2
Light Falling Weight Deflectometer	3
Briaud Compaction Device	4
PaveTracker	5
Other	N/A

Q23: Specify your agency's/company's level of interest in stiffness/strength based devices for compaction of unbound materials *Moderately Interested*

Q24: Specify your agency's level of interest in implementing stiffness/strength based devices for compaction control of unbound materials.	Moderately Interested
Q25: Ultimately, do you feel a transition to an alternative device is possible?	No
<p>Q26: Based on your experience, please rank the following factors/obstacles that you feel might hinder or negatively influence the widespread implementation of a new device/method as an alternative to the nuclear density gauge. (1: no to very low influence and 4: significantly high influence)</p>	
Need for new equipment	2
Lack of funds	3
Lack of trained personnel	4
Familiarity of devices	1
Q27: Based on your experience, please fill in the following box with any additional comment about other factors/obstacles that you believe might hinder or negatively influence the implementation of a new device/method for use as an alternative to the nuclear density gauge:	<i>Respondent skipped this question</i>

#3

**INCOMPLETE**

Collector: Web Link (Web Link)

Started: Thursday, April 24, 2014 11:46:32 AM

Last Modified: Thursday, April 24, 2014 11:48:06 AM

Time Spent: 00:01:34

IP Address: 150.250.143.16

PAGE 2: Introductory Questions

Q1: Which of the following best describes your profession?	Manufacturer of the nuclear density gauge
Q2: Please specify the level of knowledge/experience you have with the nuclear density gauge and its pavement engineering applications:	Moderately knowledgeable
Q3: Please rank the following statements regarding the use of the nuclear density gauge as compaction quality control method for unbound material. (1: not important and 4: the main reason it is used)	
The nuclear density gauge provides the user with accurate and repeatable readings	1
The nuclear density gauge provides the user with outputs in a quick timely manner	2
The data collected from the nuclear density gauge is easily analyzed and interpreted	3
The data collected from the nuclear density gauge is not influenced by the presence of moisture	4
Q4: Please rank the following statements regarding the nuclear density gauge. (1: not a problem and 5: detrimental to normal operation)	
The nuclear density gauge requires timely training/certification	1
The nuclear density gauge requires specialized and isolated storage	2
The nuclear density gauge is expensive to purchase and operate	3
The nuclear density gauge is potentially hazardous	4
The nuclear density gauge only measures density as opposed to strength/stiffness	5

Q5: If an alternative method/device, other than nuclear density gauge, is used as an unbound material compaction quality control method/device, please rank the importance of the following criteria used in selecting this method/device. (1: not important at all and 6: extremely important)

Repeatability of field measurements	1
Time Needed for field measurements	2
Ease of data processing	3
Sensitivity to environmental factors	4
Ease of use and accuracy	5
Cost	6

Q6: Please provide any additional comments, if you have any, about the factors considered in the previous question as well as other factors that might not have been considered:

Respondent skipped this question

PAGE 3: Alternatives Devices (Geogauge)

Q7: Have you previously used or researched on the Geogauge device?

Yes, I have used/researched on the Geogauge

PAGE 4: Geogauge

Q8: Based on your experiences using/researching on the Geogauge, please specify your level of agreement with the following statements:

The Geogauge provides the user with accurate and repeatable readings	Strongly Disagree
The data collected from the Geogauge is easily analyzed and interpreted	Strongly Disagree
The Geogauge provides the user with outputs in a quick timely manner	Strongly Disagree
The Geogauge is portable and easy to use	Strongly Disagree
The Geogauge is not affected by site's environmental conditions (e.g. moisture content)	Strongly Disagree
The Geogauge is negatively affected by properties of lower layers	Strongly Disagree
The Geogauge has reasonable cost	Strongly Disagree
The Geogauge provides the user with readings representative of field conditions	Strongly Disagree

Q9: Based on your experience, state the negative and positive experiences unique to this device:

Respondent skipped this question

PAGE 5: Alternatives Devices (Dynamic Cone Penetrometer)

Q10: Have you previously used or researched on the Dynamic Cone Penetrometer device?

No, I have not used/researched on the Dynamic Cone Penetrometer

PAGE 6: Dynamic Cone Penetrometer

Q11: Based on your experiences using/researching on the Dynamic Cone Penetrometer (DCP), please specify your level of agreement with the following statements

Respondent skipped this question

Q12: Based on your experience, state the negative and positive experiences unique to this device:

Respondent skipped this question

PAGE 7: Alternatives Devices (Light Falling Weight Deflectometer)

Q13: Have you previously used or researched on the Light Falling Weight Deflectometer device?

Yes, I have used/researched on the Light Falling Weight Deflectometer

PAGE 8: Light Falling Weight Deflectometer

Q14: Based on your experiences using/researching on the Light Falling Weight Deflectometer (LFWD), please specify your level of agreement with the following statements

The LFWD provides the user with accurate and repeatable readings

Strongly Disagree

The data collected from the LFWD is easily analyzed and interpreted

Strongly Disagree

The LFWD provides the user with outputs in a quick timely manner

Strongly Disagree

The LFWD is portable and easy to use

Strongly Disagree

The LFWD is not affected by site's environmental conditions (e.g. moisture content)

Strongly Disagree

The LFWD is negatively affected by properties of lower layers

Strongly Disagree

The LFWD has reasonable cost

Strongly Disagree

The LFWD provides the user with readings representative of field conditions

Strongly Disagree

Q15: Based on your experience, state the negative and positive experiences unique to this device:

Respondent skipped this question

PAGE 9: Alternatives Devices (Briaud Compaction Device)

Q16: Have you previously used or researched on the Briaud Compaction Device? *Respondent skipped this question*

PAGE 10: Briaud Compaction Device

Q17: Based on your experiences using/researching on the Briaud Compaction Device (BCD), please specify your level of agreement with the following statements *Respondent skipped this question*

Q18: Based on your experience, state the negative and positive experiences unique to this device: *Respondent skipped this question*

PAGE 11: Alternatives Devices (PaveTracker)

Q19: Have you previously used or researched on the PaveTracker? *Respondent skipped this question*

PAGE 12: PaveTracker

Q20: Based on your experiences using/researching on the PaveTracker, please specify your level of agreement with the following statements *Respondent skipped this question*

Q21: Based on your experience, state the negative and positive experiences unique to this device: *Respondent skipped this question*

PAGE 13: Conclusion Questions

Q22: Overall, rank the following devices/methods from "5" being a very poor alternative to the nuclear density gauge to "1" being an excellent alternative to the nuclear density gauge. Please pick N/A if you haven't had any prior experience with a particular device. *Respondent skipped this question*

Q23: Specify your agency's/company's level of interest in stiffness/strength based devices for compaction of unbound materials *Respondent skipped this question*

Q24: Specify your agency's level of interest in implementing stiffness/strength based devices for compaction control of unbound materials. *Respondent skipped this question*

Q25: Ultimately, do you feel a transition to an alternative device is possible?

Respondent skipped this question

Q26: Based on your experience, please rank the following factors/obstacles that you feel might hinder or negatively influence the widespread implementation of a new device/method as an alternative to the nuclear density gauge. (1: no to very low influence and 4: significantly high influence)

Respondent skipped this question

Q27: Based on your experience, please fill in the following box with any additional comment about other factors/obstacles that you believe might hinder or negatively influence the implementation of a new device/method for use as an alternative to the nuclear density gauge:

Respondent skipped this question

Appendix B

Compaction Quality Control of Unbound Subgrade and Base/Subbase Layers Through Use of the Dynamic Cone Penetrometer.

1. SCOPE.

- 1.1 This specification covers the compaction quality control of aggregate pavement layers consisting of unbound subgrade and base/subbase materials through the use of the Dynamic Cone Penetrometer (DCP).

2. REFERENCED DOCUMENTS.

2.1 ASTM Standards.

D 6951 Use of the Dynamic Cone Penetrometer in Shallow Pavement Applications

D 7380 Soil Compaction Determination at Shallow Depths Using 5-lb (2.3 kg) Dynamic Cone Penetrometer

D 1557 Standard Test Methods for Laboratory Compaction Characteristics of Soil Using Modified Effort

2.2 AASHTO Standards.

T 2 Standard Method of Test for Sampling of Aggregates

2.3 NJDOT Standards.

200 Standard Specifications for Road and Bridge Construction: Earthwork

300 Standard Specifications for Road and Bridge Construction: Subbase and Base Courses

3. SIGNIFICANCE AND USE.

1. This procedure is utilized for the acceptance of compacted unbound subgrade and base/subbase pavement layers.

4. DEVICE.

1. The Dynamic Cone Penetrometer includes a 22.6-inch (575-mm) upper fixed steel rod containing a 17.6 lbs. (8-kg) steel hammer. Located at lower end of the

device is a 0.629-inch (16-mm) diameter rod with an anvil that acts as a lower stopping mechanism for the falling hammer. In addition, the anvil serves as a connector between the two rods and allows the device to be dissembled for easy transport. The length of the lower rod is 24-inch (609.6-mm). At the base of the lower rod is a 0.79-inch (20-mm) diameter steel cone with an apex angle of 60 degrees (Note - 1). The device is tested in accordance to ASTM D6951 or ASTM D7380 standards. The device is to be retrofitted with an automatic ruler that is marked in 0.2-inch (5-mm) increments to indicate the required penetration of the device onto the steel rod and resulting penetration per blow values.

Note 1 – The cone tip may be replaced throughout testing as it becomes trapped in the soil during the extraction of the DCP from the compacted layer. This generally pertains to more coarse materials that contain larger aggregate particles that restrict the cones upward movement.

5. MATERIALS.

1. The Contractor is to use aggregate material that conforms to the requirements of the specifications listed in Table 6.1.

Table 6.1 Material Specifications.

Material	Specification
NJDOT Subgrade	NJDOT 901.11
NJDOT Base/Subbase	NJDOT 901.11

2. Unless specified otherwise, the Contractor is to provide necessary stockpile at the designated site that meets the specifications provided in Table 6.1.
3. The Contractor accepts full responsibility for the placement and compaction of acceptable material at the designated site.
4. Should the material not meet the specifications listed in Table 6.1 the RE may require the Contractor to replace or exclude such material prior to compaction of the subgrade or base/subbase layer.

6. PROCEDURE.

1. Assemble the DCP equipment and attach the replaceable cone tip to the foot of the lower rod as shown in Figure B.1 below. Before proceeding with testing, ensure all parts are securely fastened.
2. Unless specified otherwise, it is recommended to conduct DCP testing by any one of the following methods:

621. Control Strip. A control strip of 400-square yards (334.5-square meters) or greater is to be constructed to perform the DCP test at 10 randomly selected locations (Note - 2).

Note 2 – The procedure for conducting DCP testing shall be in accordance to methods specified in 203.03.02.B of the NJDOT specifications for determining compaction requirements based on density acceptance.

622. Random Selection of Test Points. DCP testing should be conducted at 10 randomly selected locations within the designated site at a minimum of 3-ft. (0.9-m) increments of each other (Note – 3).

Note 3 – It is recommended to conduct DCP testing in a similar fashion as to the methods specified in 203.03.02.D or 302.03.01B of the NJDOT specifications.

3. Using either method provided in Section 6.2, calculate an average DCP value from the complete set of testing results measured at the designated site.
4. The DCP test shall be conducted until a depth of 15-inches (38.1-cm) of the compacted material is reached.
5. For areas in which the depth of the layer is less than 15-inches (38.1-cm) it is recommended to conduct the DCP test for the entire thickness of the layer.
6. Testing shall be conducted using the DCP at the designated site within 24 hours of placement and final compaction.
7. Testing should not to be conducted later than 24 hours to avoid overestimating DCP measurements.

7. ACCEPTANCE CRITERIA.

1. **Gradation.** Use aggregate material that is in accordance to the gradation designations I-1 through I-15 of the NJDOT specifications.
2. The gradation specifications shall apply to the material following the placement and compaction at the designated site (Note – 4).

Note 4 – If compaction is not anticipated the aggregates material should meet the gradation specifications during its placement at the designated site.

3. Acceptable gradation specifications are to be maintained through implementing one of the random sampling procedures as specified in AASHTO T 2.

4. **Moisture Content Control.** The material will be deemed acceptable based on one of the following two acceptance criteria:

7.4.1. Implicit Moisture Content Control. Acceptable materials are to conform to the requirements of the specifications presented in Table 7.4.1

Table 7.4.1 Minimum Acceptable DCP Values.

Material	Percent Passing (%)				Minimum DCP Value (blows/inch.)	Minimum DCP Blows for (1-ft layer) (rounded to the nearest 5 DCP blows)
	Sieve No. 4 (4.75 mm)		Sieve No. 200 (75 µm)			
	Min.	Max.	Min.	Max.		
NJDOT Subgrade	40	100	0	8	1.5	18 (20)
NJDOT Base/Subbase	25	50	3	10	3.4	41 (40)

7.4.2. Explicit Moisture Content Control. Acceptable materials are in compliance with the requirements of the specifications presented in Table 7.4.2 (Note – 5).

Note 5 – Samples for moisture content will be taken at random prior to compaction, in accordance with random sampling procedures provided in AASHTO T 2.

Table 7.4.2 Minimum Acceptable DCP Values.

Material	Percent Passing (%)				Moist. Cont. Diff. (%)		Minimum DCP Value (blows/inch.)	Minimum DCP Blows for (1-ft layer) (rounded to the nearest 5 DCP blows)
	Sieve No. 4 (4.75 mm)		Sieve No. 200 (75 µm)					
	Min.	Max.	Min.	Max.	Min.	Max.		
NJDOT Subgrade	40	100	0	8	0	2	1.3	16 (15)
	40	100	0	8	-2	0	1.5	18 (20)
	40	100	0	8	-4	-2	1.9	23 (25)
	40	100	0	8	-6	-4	2.2	27 (25)
NJDOT Base/Subbase	25	50	3	10	0	2	3.2	39 (40)
	25	50	3	10	-2	0	3.4	41 (40)
	25	50	3	10	-4	-2	3.8	46 (45)
	25	50	3	10	-6	-4	4.1	50 (50)

5. Acceptable material shall contain an average DCP value, as measured in Section 6.2, equal to or greater than the minimum acceptable DCP values specified.
6. For the materials that do not meet the specifications provided it is recommended to correct the material as needed in order to achieve the minimum acceptable DCP value.
8. **DOCUMENT.** While conducting the DCP test document the following information and submit to the RE:
 1. The number of hammer blows required to penetrate the layer between test readings.
 2. Cumulative depth of penetration after each set of hammer blows.
 3. Difference in cumulative penetration between each reading.
 4. The penetration depth per blow (Note – 6).

(Note 6 – This value is obtained by dividing the penetration between each reading by the number of blows measured.)
 5. The rate of penetration between each test reading.
 6. Assessment on acceptable/unacceptable compacted material.

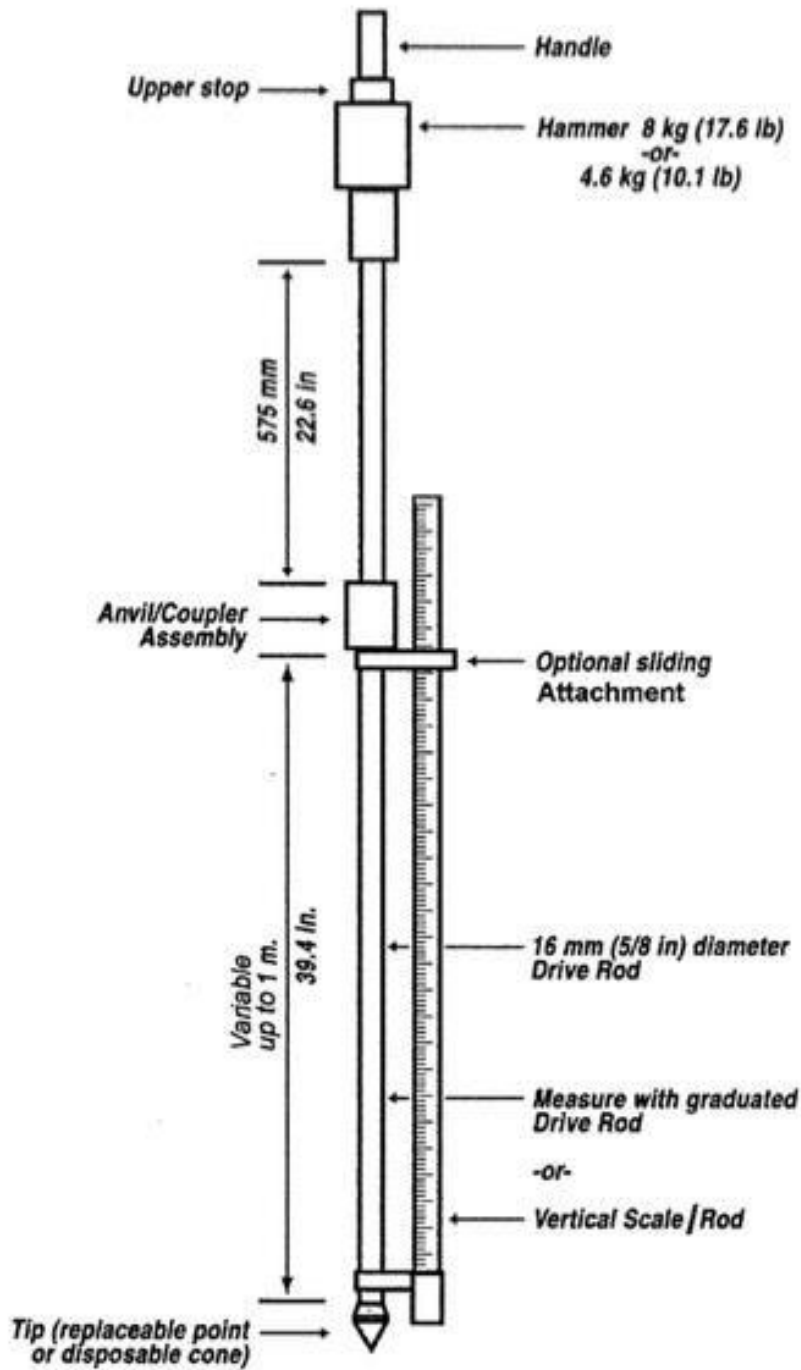

Figure B.1: Assembly Schematic of the DCP [33]